

<u>FEATURES</u>	KNOCK-DOWN ROOF CURBS FOR YORK CHOICE UNITS	PROVENT P/N	A	EST. WEIGHT	SEISMIC KIT P/N
<ul style="list-style-type: none"> • Roof curb perimeter made of galvanized steel. • Gasketing package provided. • Heat treated wood nailer provided. • Corner flanges are pre-threaded for easy bolt on assembly. • Pitched, adjustable pitch/ adjustable height, welded, different height, isolation and calculated curbs are available. 	AV, KV20-25; AW, KW13-15; AH, AL, KH18-20; HV, WV15-20	CBKDSAV202508**	08"	220 Lbs.	KDKITSAV2025 When conforming to CBC 2022 and IBC 2021, include optional seismic kit. Available for 8"- 18"
		CBKDSAV202511**	11"	250 Lbs.	
		CBKDSAV202514**	14"	280 Lbs.	
		CBKDSAV202518**	18"	400 Lbs.	
		CBKDSAV202524**	24"	500 Lbs.	
<u>NOTES</u>					
<ul style="list-style-type: none"> • Attach ductwork to roof curb. Flanges of duct rest on top of curb. Support ductwork below the curb. • CBKDSAV202518 & CBKDSAV202524 will be 12GA perimeter 					

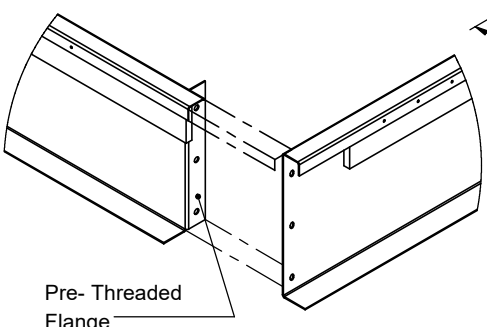

CORNER DETAIL

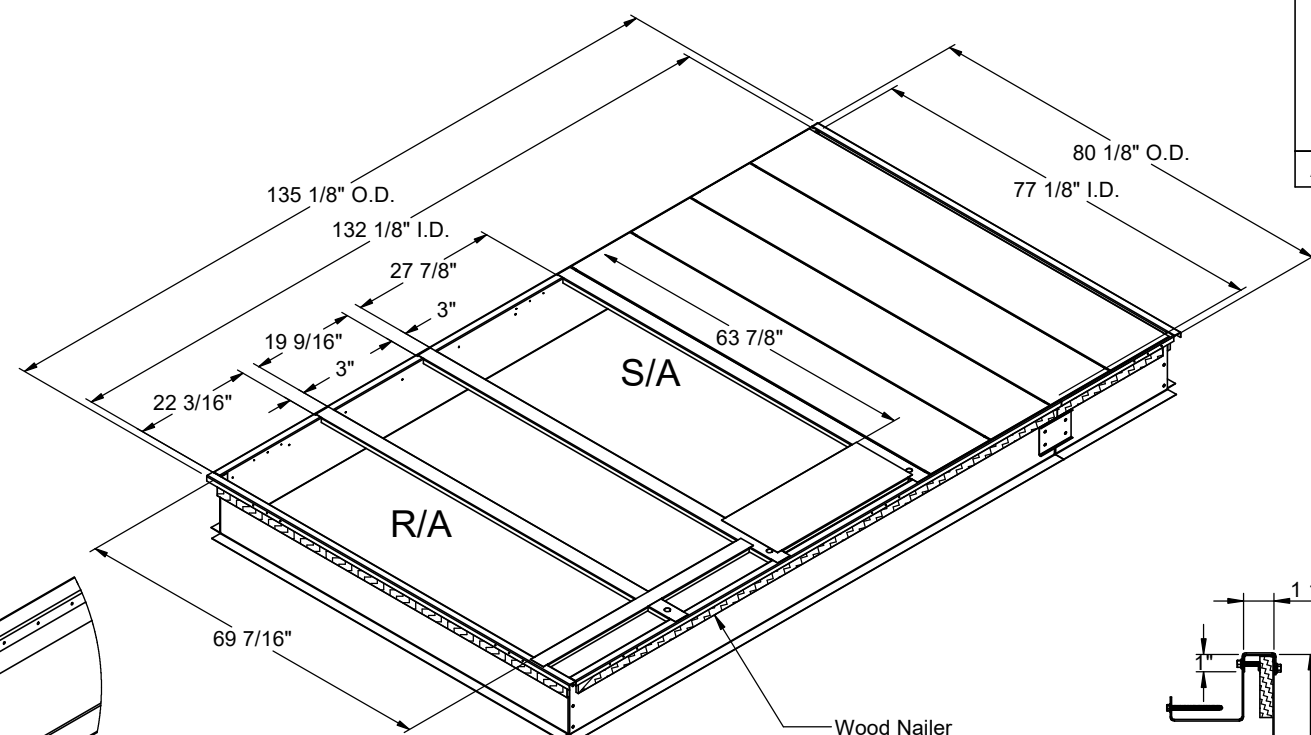

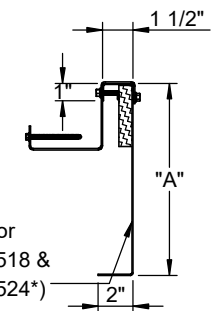

CROSS SECTION DETAIL

	3847 WABASH DRIVE MIRA LOMA, CA 91752	SUBMITTED TO: _____ COMPANY: _____ JOB NAME: _____ EQUIPMENT: _____ NOTES: _____	FORM NO: -	PART NUMBER: CBKDSAV2025 SERIES
	PHONE (951) 685-1101 FAX (619) 872-9799	DATE: 11/13/2024	REV: 3	DRAWN BY: CNG