

- FEATURES**
- Roof curb perimeter made of galvanized steel.
 - Gasketing package provided.
 - Heat treated wood nailer provided.
 - Corner flanges are pre-threaded for easy bolt on assembly.
 - Pitched, adjustable pitch/adjustable height, welded, different height, isolation and calculated curbs are available.

- NOTES**
- Attach ductwork to roof curb. Flanges of duct rest on top of the curb. Support ductwork below the curb.

KNOCK-DOWN ROOF CURBS FOR YORK UNITS

PG3E, PC3E, PCG4B, PCE4B 48-60
PCG6B, PCE6B, PHE4/6B, PHG4/6B 36-60

PROVENT P/N	A	EST. WEIGHT
CBKDLXL08	8"	53 Lbs.
CBKDLXL11	11"	64 Lbs.
CBKDLXL14	14"	75 Lbs.
CBKDLXL18	18"	95 Lbs.
CBKDLXL24	24"	114 Lbs.

SEISMIC CLIP KIT P/N
KDKITLX

When conforming to CBC 2022 and IBC 2021, include optional seismic hold down clip kit.

Available on 8" - 14"

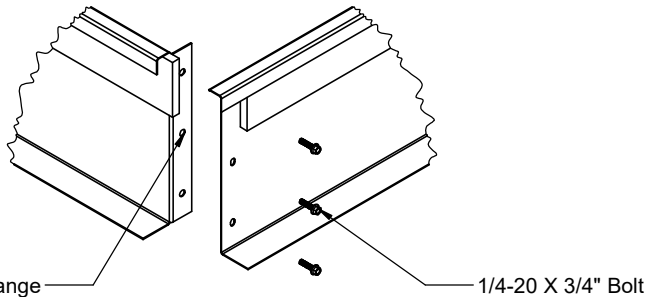
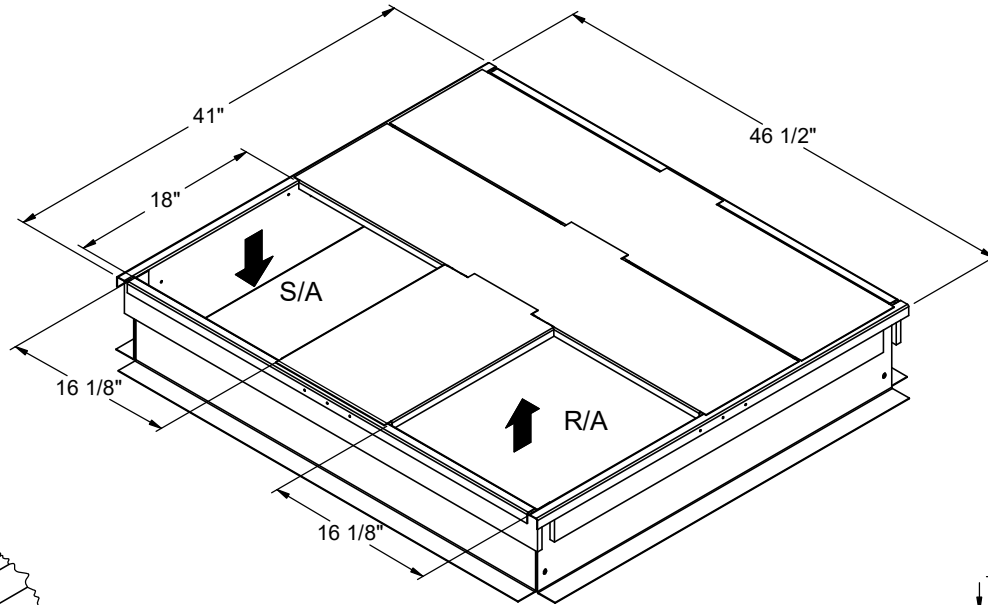

CORNER DETAIL

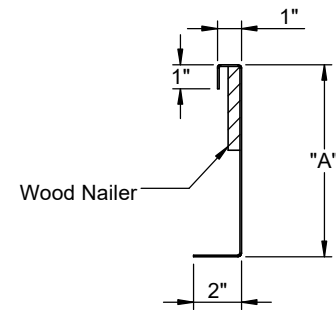

CROSS SECTION DETAIL



3847 WABASH DR.
MIRA LOMA, CA 91725

PHONE (951) 685-1101
FAX (619) 872-9799

SUBMITTED TO: _____
COMPANY: _____
JOB NAME: _____
EQUIPMENT: _____
NOTES: _____

FORM NO:
CBKD-151

DATE:
1/13/2025

PART NUMBER:
CBKDLXL SERIES

REV:
6

DRAWN BY:
CNG