

FEATURES

- Roof curb perimeter made of galvanized steel.
- Gasketing package provided.
- Heat treated wood nailer provided.
- Corner flanges are pre-threaded for easy bolt on assembly.
- Pitched, adjustable pitch/adjustable height, welded, different height, isolation and calculated curbs are available.

NOTES

- Attach ductwork to roof curb. Flanges of duct rest on top of the curb. Support ductwork below the curb.

KNOCK-DOWN ROOF CURBS FOR YORK UNITS

PG3E, PC3E, PCG4A, PCE4A 24-42
PCG6A, PCE6A, PHE4/6A, PHG4/6A 24-30

PROVENT P/N	A	EST. WEIGHT	SEISMIC CLIP KIT P/N
CBKDLXS08	8"	43 Lbs.	KDKITLX
CBKDLXS11	11"	54 Lbs.	
CBKDLXS14	14"	65 Lbs.	
CBKDLXS18	18"	85 Lbs.	X
CBKDLXS24	24"	104 Lbs.	

When conforming to CBC 2022 and IBC 2021, include optional seismic hold down clip kit.

Available on 8" - 14"

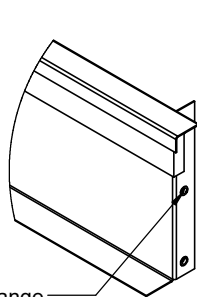
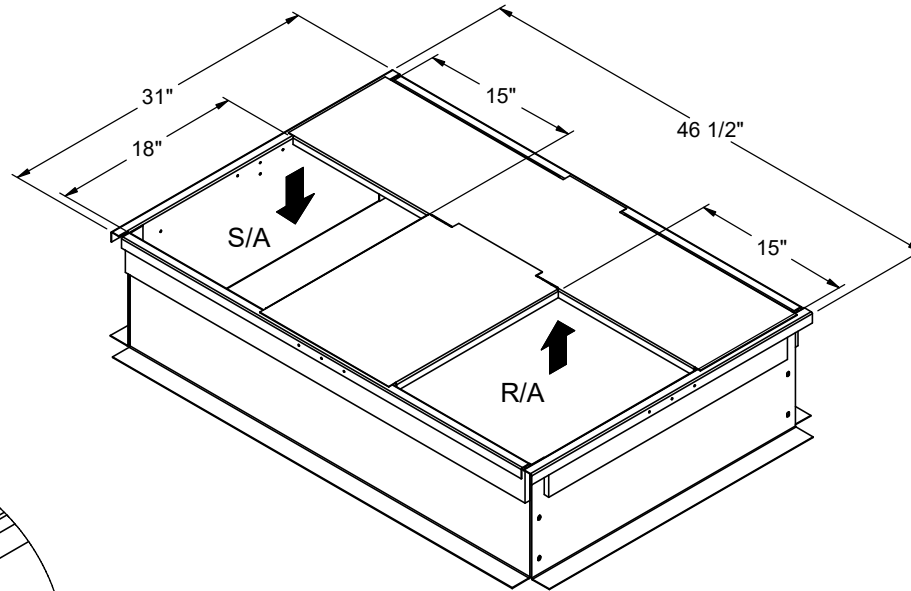

Pre-Threaded Flange

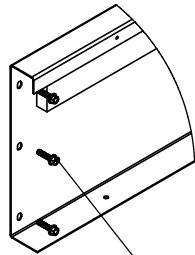

1/4-20 X 3/4" Bolt

CORNER DETAIL

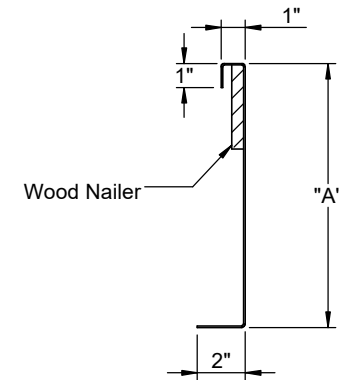

Wood Nailer

CROSS SECTION DETAIL



3847 WABASH DR.
MIRA LOMA, CA 91725

PHONE (951) 685-1101
FAX (619) 872-9799

SUBMITTED TO: _____
COMPANY: _____
JOB NAME: _____
EQUIPMENT: _____
NOTES: _____

FORM NO:
CBKD-150

DATE:
1/8/2025

PART NUMBER:
CBKDLXS SERIES

REV:
7

DRAWN BY:
CNG