

FEATURES	KNOCK- DOWN ROOF CURBS FOR YORK UNITS	PROVENT P/N	A	EST. WEIGHT	SEISMIC CLIP KIT P/N
----------	---------------------------------------	-------------	---	-------------	----------------------

- Roof curb perimeter made of galvanized steel.
- Gasketing package provided.
- Heat treated wood nailer provided.
- Corner flanges are pre- treated for easy bolt on assembly.
- Pitched, adjustable pitch/ adjustable height, welded, different height, Isolation and calculated curbs are available.

ZR, XN, XP, WN 036-060
ZE, ZF, KE 036-072

CBKDSUN367208	8"	67 Lbs.
CBKDSUN367211	11"	79 Lbs.
CBKDSUN367214	14"	91 Lbs.
CBKDSUN367224	24"	132 Lbs.

KDKITSUN3672

When conforming to CBC 2022 and IBC 2021, include optional seismic hold down clip kit.
Available on 8"- 14"

NOTES

- Attach ductwork to roof curb. Flanges of duct rest on top of curb. Support ductwork below the curb.

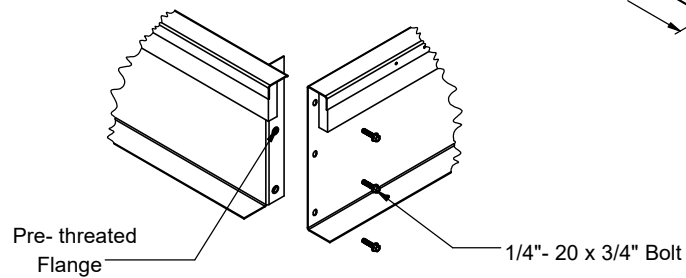
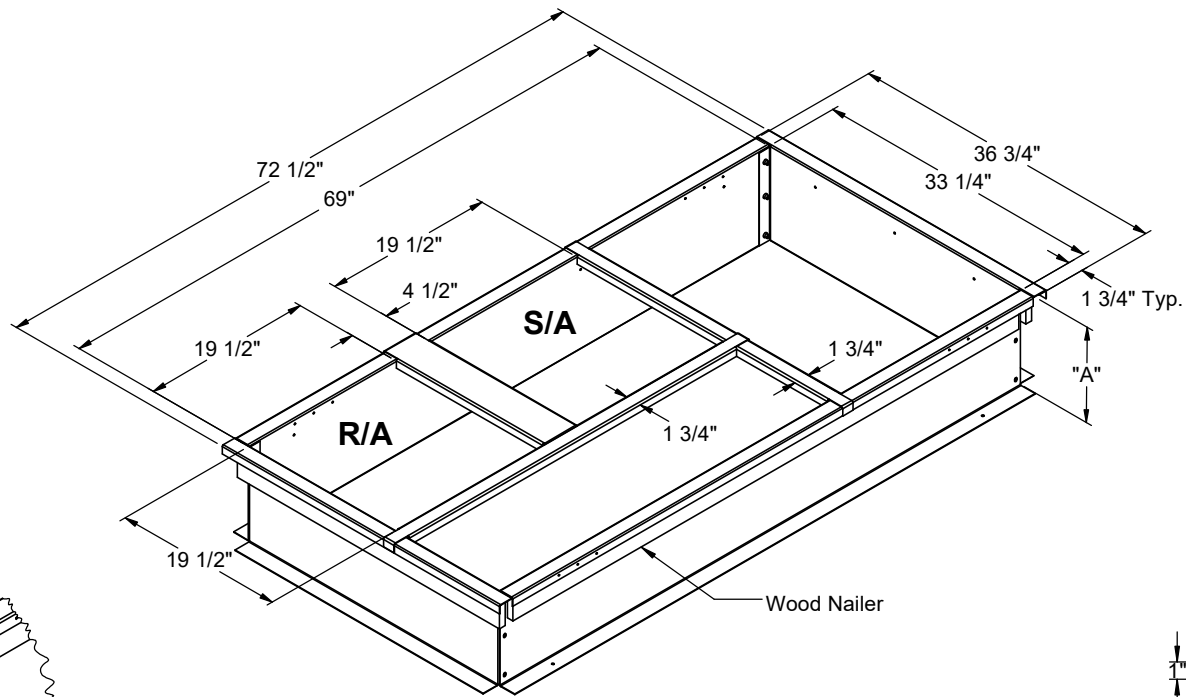

CORNER DETAIL

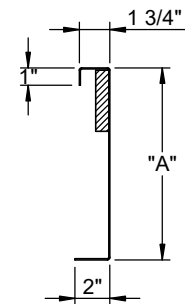

CROSS SECTION DETAIL

	3847 WABASH DR. MIRA LOMA, CA 91752	SUBMITTED TO: _____ COMPANY: _____ JOB NAME: _____	FORM NO: CBKD-102	PART NUMBER: CBKDSUN3672 SERIES	
	PHONE (951) 685-1101 FAX (619) 872-9799	EQUIPMENT: _____ NOTES: _____	DATE: 1/7/2025	REV: 5	DRAWN BY: CNG