

**FEATURES**

- Fully welded construction.
- 10 Ga. galvanized support frame.
- Estimated weight - 305 Lbs.
- Gasketing package provided.

**VIBRATION ISOLATION FRAME FOR HORIZONTAL YORK  
CHOICE UNITS- LOW PROFILE**

**AV, KV20-25; AW, KW13-15  
AH, AL, KH, KL18-20; HV, WV15-20**

Unit Model	Power Exhaust?	Provent P/N
AV, KV20-25; HV, WV15	NO	CBISHSAV20251
AW, KW13-15; HV, WV20 AH, AL, KH, KL18-20	NO	CBISHSAV20252
AV, KV20-25; HV, WV15	YES	CBISHSAV2025P1
AW, KW13-15; HV, WV20 AH, AL, KH, KL18-20	YES	CBISHSAV2025P2

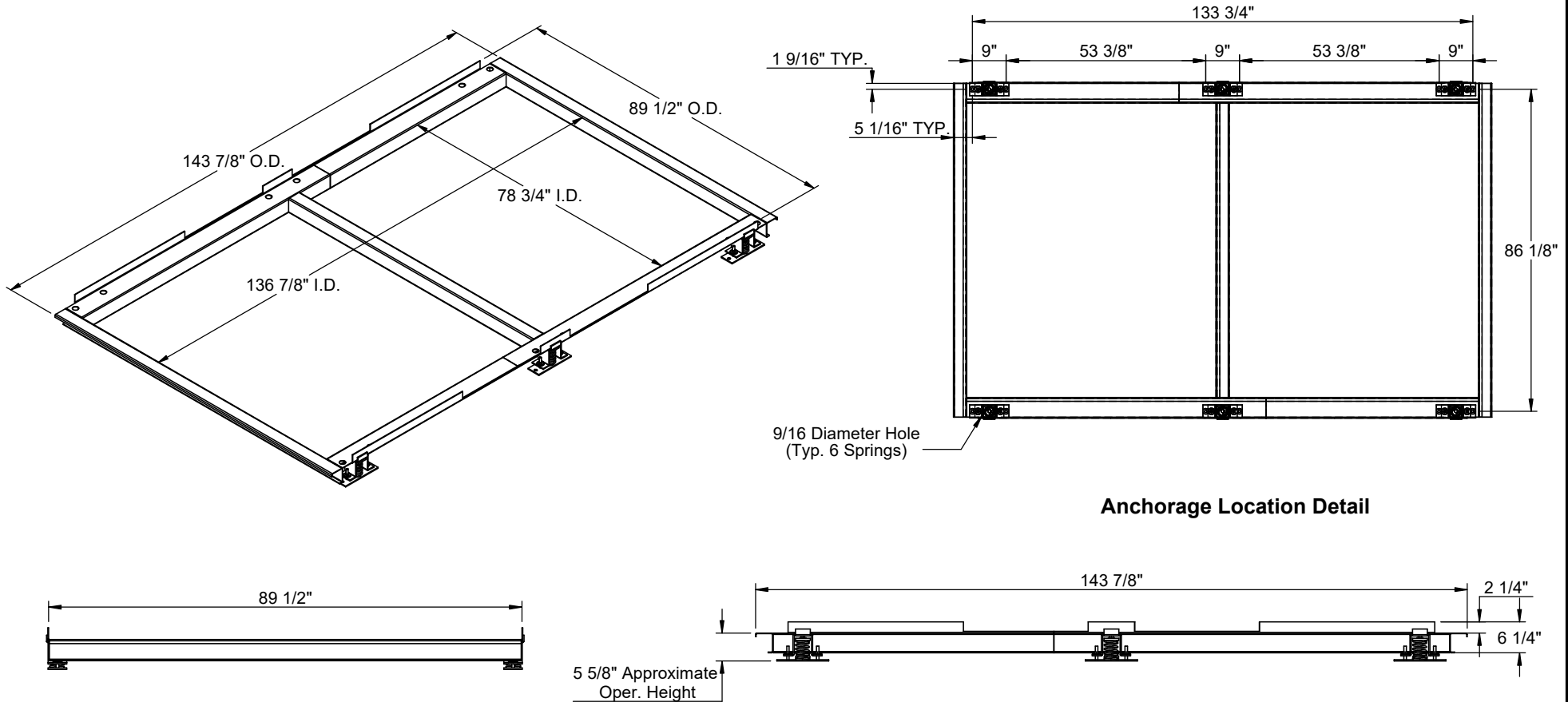

**Anchorage Location Detail**



**3847 WABASH DR.  
MIRA LOMA, CA 91752**

**PHONE (951) 685-1101  
FAX (619) 872-9799**

SUBMITTED TO: \_\_\_\_\_  
 COMPANY: \_\_\_\_\_  
 JOB NAME: \_\_\_\_\_  
 EQUIPMENT: \_\_\_\_\_  
 NOTES: \_\_\_\_\_

FORM NO:  
CBISH-125

DATE:  
2/6/2025

PART NUMBER:  
CBISHSAV2025 SERIES

REV:  
3

DRAWN BY:  
CNG