

FEATURES

- Fully welded construction.
- 10 Ga. galvanized support frame.
- Estimated weight - 211 Lbs.
- Gasketing package provided.

VIBRATION ISOLATION RAIL FOR HORIZONTAL YORK UNITS - LOW PROFILE

ZX, KX08-14; XX, WX08-12; XY, WY, ZY, KYA7
ZY, KY07-12; XY, WY07-09; ZL, KL08-14

Unit Model	Power Exhaust?	Provent P/N
ZX, KX08; ZY, XY, KY, WY07 XY, WY, ZY, KYA7	NO	CBISHPRL1
ZX, KX09-14; ZY, KY08-12 XX, WX08-12; ZL, KL08-14 XY, WY08-09	NO	CBISHPRL2
ZX, KX08; ZY, XY, KY, WY07 XY, WY, ZY, KYA7	YES	CBISHPRLP1
ZX, KX09-14; ZY, KY08-12 XX, WX08-12; ZL, KL08-14 XY, WY08-09	YES	CBISHPRLP2

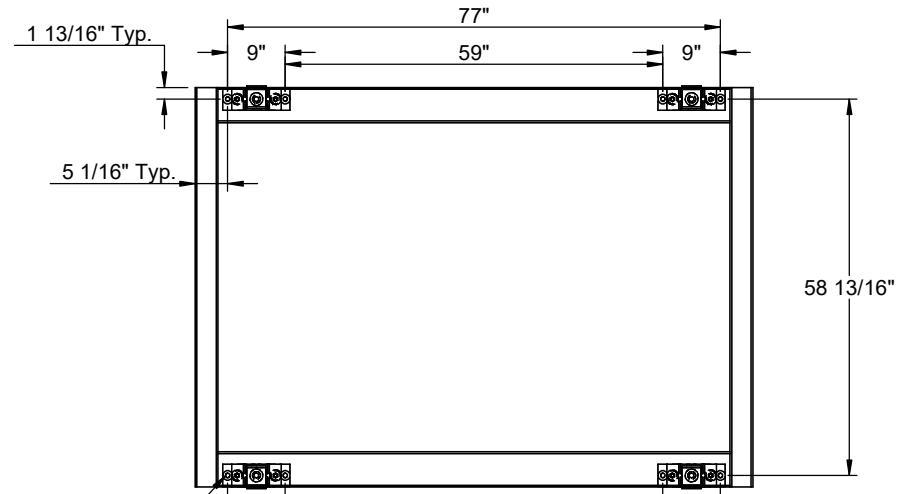
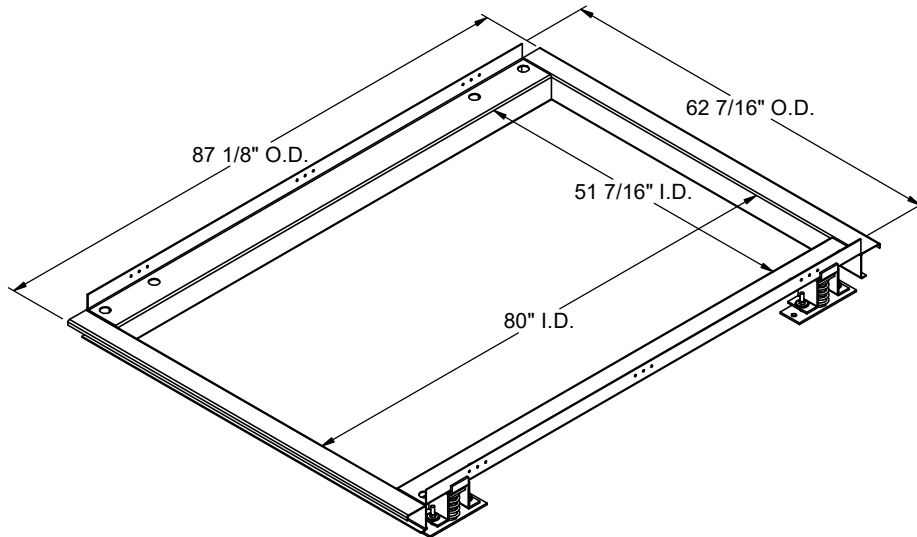

11/16 Diameter Hole
(Typ. 4 Springs)

Anchorage Location Detail

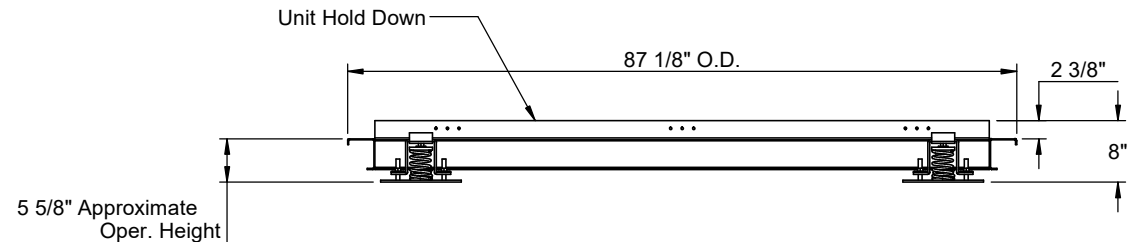
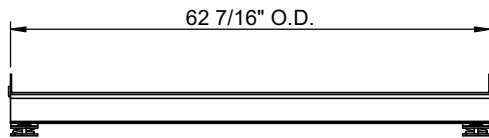

3847 WABASH DR.
MIRA LOMA, CA 91752

PHONE (951) 685-1101
FAX (619) 872-9799

SUBMITTED TO: _____
COMPANY: _____
JOB NAME: _____
EQUIPMENT: _____
NOTES: _____

FORM NO:
CBISH-123

PART NUMBER:
CBISHPRL - SERIES

DATE:
1/13/2025

REV:
4

DRAWN BY:
CNG