

**FEATURES**

- Fully welded construction.
- 14 Ga. galvanized support frame.
- Estimated weight - 97 Lbs.
- Gasketing package provided.

**VIBRATION ISOLATION RAIL FOR HORIZONTAL YORK UNITS - LOW PROFILE**

PG3E, PC3E, PCG4B, PCE4B 48-60  
PCG6B, PCE6B, PHE4/6B, PHG4/6B 36-60

Unit Model

Power Exhaust?

Provent P/N

ALL B CABINET MODELS

NO

CBISHLXL1

ALL B CABINET MODELS

YES

CBISHLXLP1

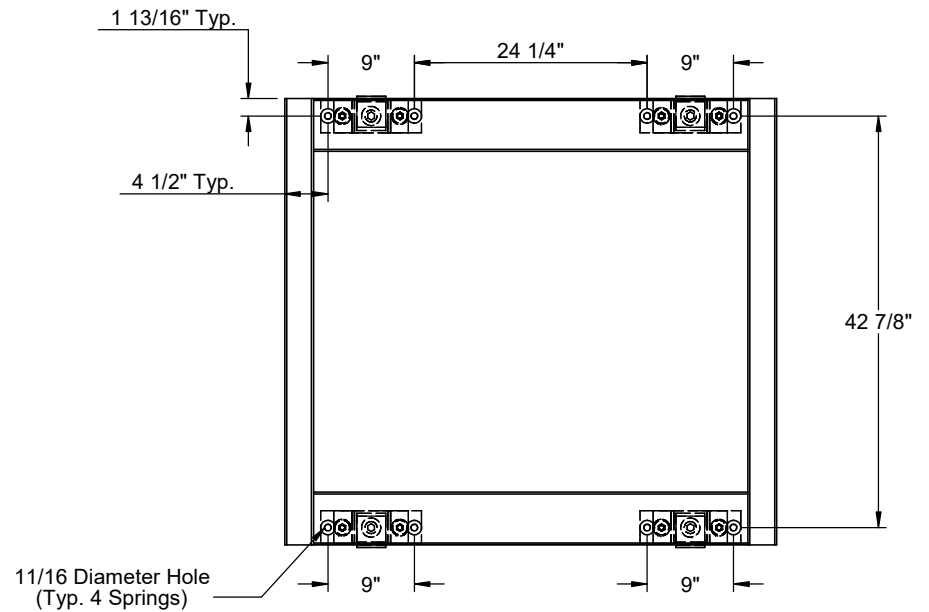
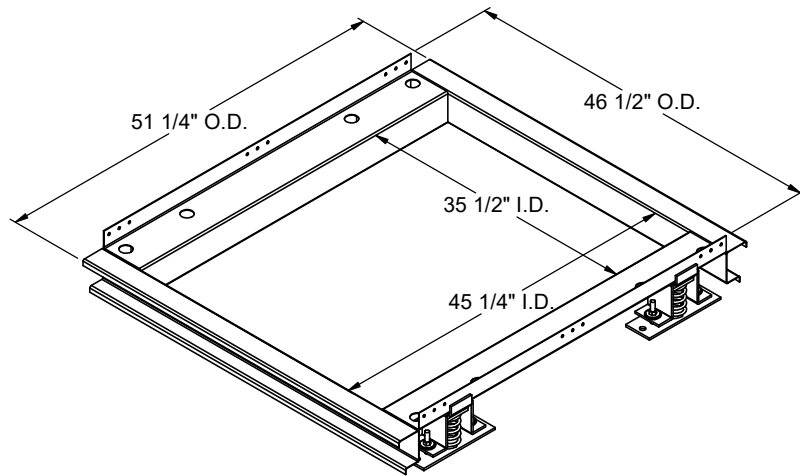

**Anchorage Location Detail**

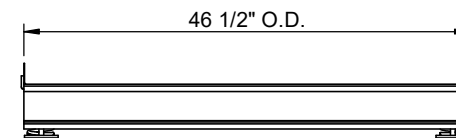
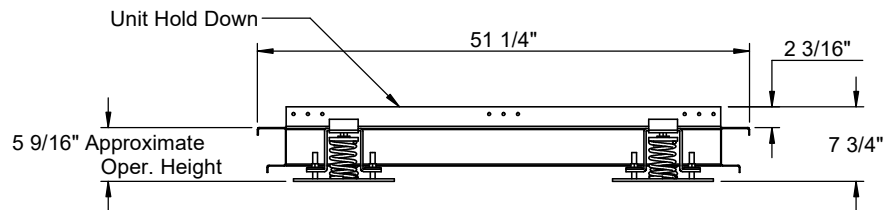

3847 WABASH DRIVE  
MIRA LOMA, CA 91752

PHONE (951) 685-1101  
FAX (619) 872-9799

SUBMITTED TO: \_\_\_\_\_  
COMPANY: \_\_\_\_\_  
JOB NAME: \_\_\_\_\_  
EQUIPMENT: \_\_\_\_\_  
NOTES: \_\_\_\_\_

FORM NO:  
CBISH-121

PART NUMBER:  
CBISHLXL - SERIES

DATE:  
1/13/2025

REV:  
2

DRAWN BY:  
CNG