

**FEATURES**

- Fully welded construction.
- 14 Ga. galvanized support frame.
- Estimated weight - 92 Lbs.
- Gasketing package provided.

**VIBRATION ISOLATION RAIL FOR HORIZONTAL YORK UNITS - LOW PROFILE**

PG3E, PC3E, PCG4A, PCE4A 24-42  
PCG6A, PCE6A, PHE4/6A, PHG4/6A 24-30

Unit Model

Power Exhaust?

Provent P/N

ALL A CABINET MODELS

NO

CBISHLXS1

ALL A CABINET MODELS

YES

CBISHLXSP1

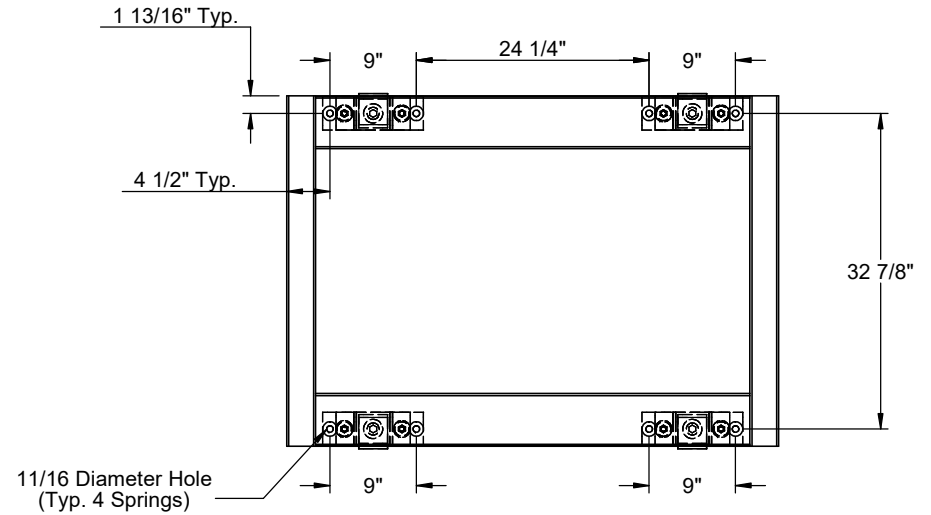
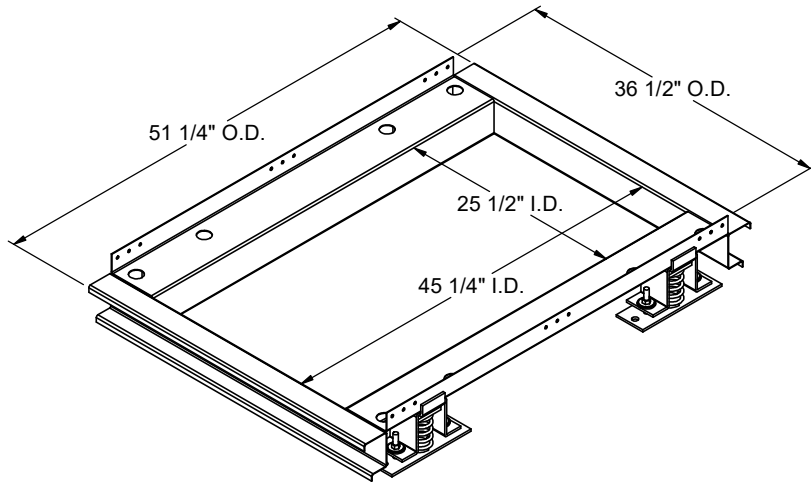

**Anchorage Location Detail**

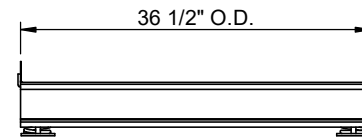
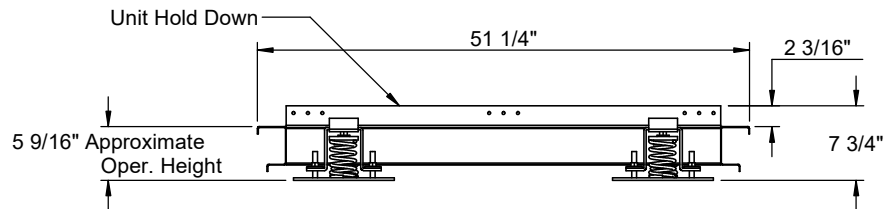

3847 WABASH DRIVE  
MIRA LOMA, CA 91752

PHONE (951) 685-1101  
FAX (619) 872-9799

SUBMITTED TO: \_\_\_\_\_  
COMPANY: \_\_\_\_\_  
JOB NAME: \_\_\_\_\_  
EQUIPMENT: \_\_\_\_\_  
NOTES: \_\_\_\_\_

FORM NO:  
CBISH-120

PART NUMBER:  
CBISHLXS - SERIES

DATE:  
1/13/2025

REV:  
2

DRAWN BY:  
CNG