

FEATURES

- Fully welded construction.
- 10 Ga. galvanized support frame.
- Estimated weight - 189 Lbs.
- Gasketing package provided.

VIBRATION ISOLATION RAIL FOR HORIZONTAL YORK UNITS - LOW PROFILE

ZT, ZH, ZJ, ZR, KT, KJ 037-150
ZF, XP, ZB, WP, KB 078-150

Unit Model	Power Exhaust?	Provent P/N
ZH, ZJ, ZR KJ 078-090; ZF 078-102 ZT, KT 037, 049, 061; ZB, KB 078	NO	CBISHPRD37151
ZH, ZJ, ZR, KJ 102-120; XP, WP 078-120 ZT, KT, 078-102; ZB, KB 090-120	NO	CBISHPRD37152
ZF, ZT, KT 120-150 ZH, ZJ, ZR, XP; ZB, KJ, WP, KB 150	NO	CBISHPRD37153
KJ, ZR, ZH, ZJ 037, 049, 061	NO	CBISHPRD37154
ZH, ZJ, ZR KJ 078-090; ZF 078-102 ZT, KT 037, 049, 061; ZB, KB 078	YES	CBISHPRD3715P1
ZH, ZJ, ZR, KJ 102-120; XP, WP 078-120 ZT, KT, 078-102; ZB, KB 090-120	YES	CBISHPRD3715P2
ZF, ZT, KT 120-150 ZH, ZJ, ZR, XP, ZB, KJ, WP, KB 150	YES	CBISHPRD3715P3
KJ, ZR, ZH, ZJ 037, 049, 061	YES	CBISHPRD3715P4

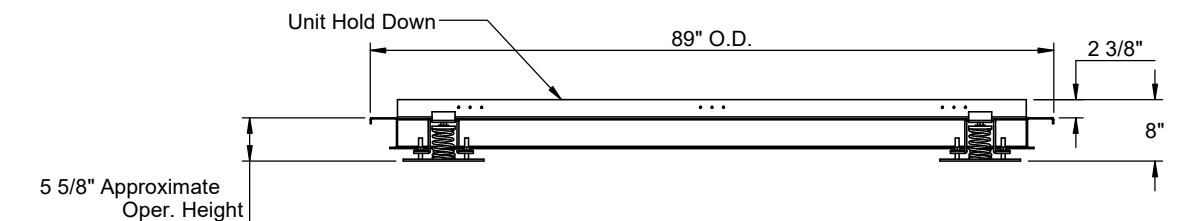
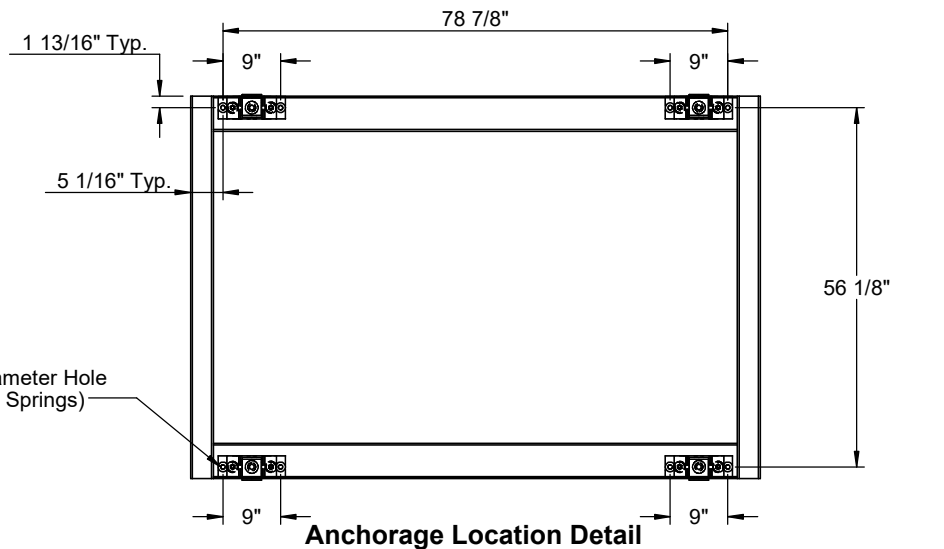
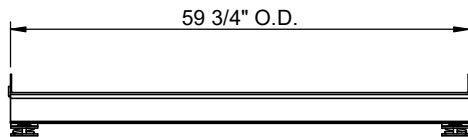
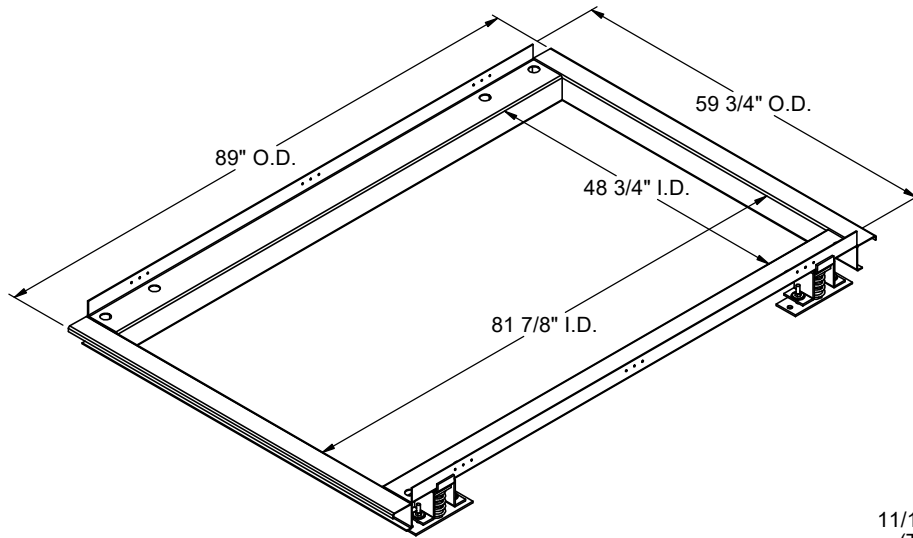

3847 WABASH DR.
MIRA LOMA, CA 91752

PHONE (951) 685-1101
FAX (619) 872-9799

SUBMITTED TO: _____
COMPANY: _____
JOB NAME: _____
EQUIPMENT: _____
NOTES: _____

FORM NO:
CBISH-110

DATE:
1/13/2025

PART NUMBER:
CBISHPRD3715 - SERIES

REV:
4

DRAWN BY:
CNG