

**FEATURES**

- Roof curbs sides and ends are 14 ga.
- Fully welded construction.
- Gasketing package provided.
- Heat treated wood nailer provided.
- insulated deck pans provided.
- Pitched curbs and taller curbs are available.

**NOTES**

- Attach ductwork to roof curb. Flanges of duct rest on top of the curb, Support ductwork below the curb.
- Thru the curb utilities are available. Contact your York distributor or Provent directly.

**VIBRATION ISOLATION ROOF CURBS YORK CHOICE UNITS**

AV, KV28; AW, KW18-23; AH, AL, KH25; HV, WV25

PROVENT P/N

A

B

EST. WEIGHT

CBISSAV2818**	8"	18"	653 Lbs.
CBISSAV2821**	11"	21"	688 Lbs.
CBISSAV2824**	14"	24"	723 Lbs.

\*\*Note: Spring configuration must be added to part number at time of order - See current price guide

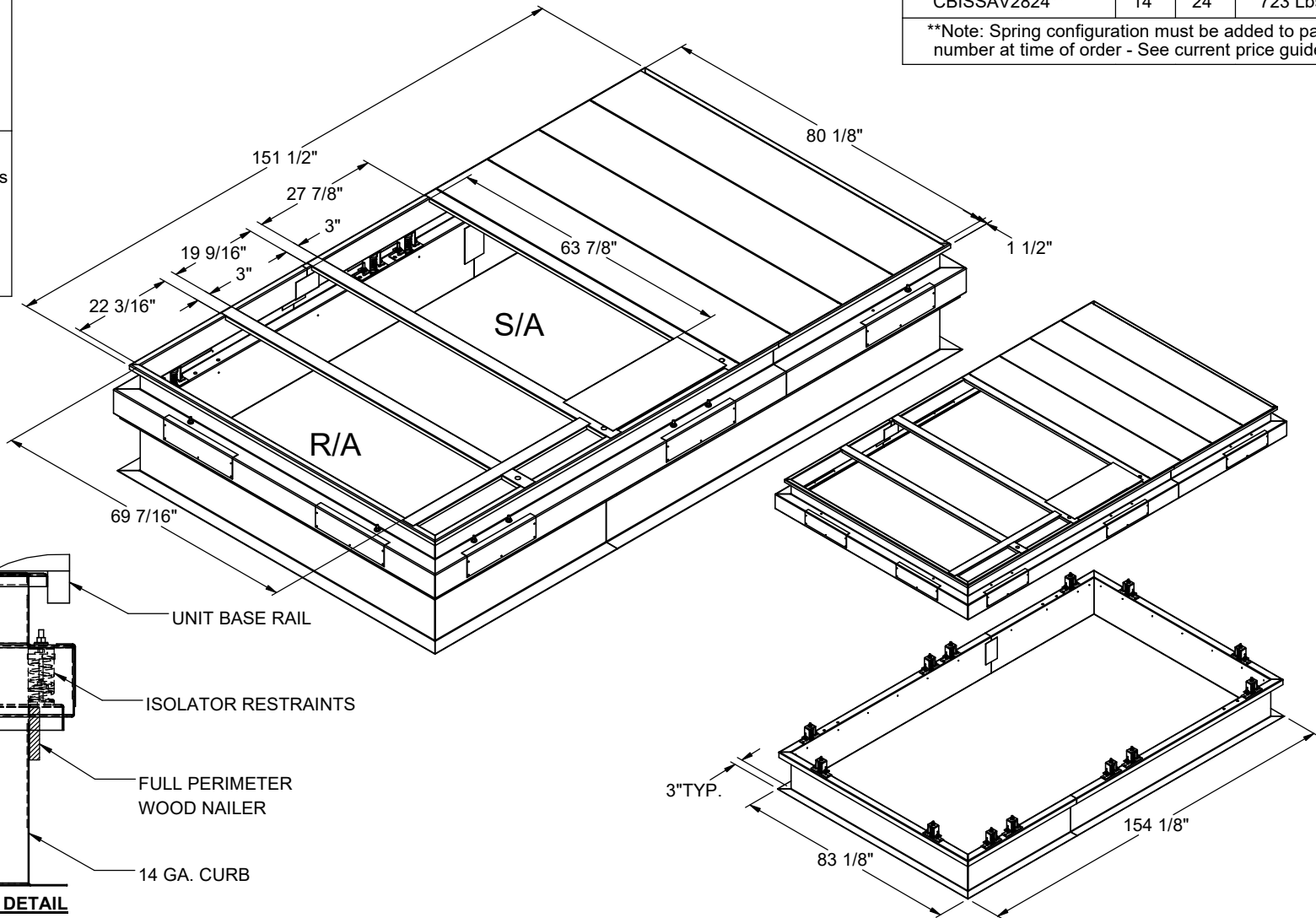

3847 WABASH DRIVE  
MIRA LOMA, CA 91752

PHONE (951) 685-1101  
FAX (619) 872-9799

SUBMITTED TO: \_\_\_\_\_  
 COMPANY: \_\_\_\_\_  
 JOB NAME: \_\_\_\_\_  
 EQUIPMENT: \_\_\_\_\_  
 NOTES: \_\_\_\_\_

FORM NO:

-

DATE:

11/25/2024

PART NUMBER:

CBISSAV28 SERIES

REV:

M1

DRAWN BY:

CNG