

FEATURES

- Roof curbs sides and ends are 14 ga.
- Fully welded construction.
- Gasketing package provided.
- Heat treated wood nailer provided.
- insulated deck pans provided.
- Pitched curbs and taller curbs are available.

NOTES

- Attach ductwork to roof curb. Flanges of duct rest on top of the curb, Support ductwork below the curb.
- Thru the curb utilities are available. Contact your York distributor or Provent directly.

VIBRATION ISOLATION ROOF CURBS YORK CHOICE UNITS

AV, KV20-25; AW, KW13-15; AH, AL, KH, KL18-20; HV, WV15-20

PROVENT P/N

A

B

EST. WEIGHT

CBISSAV202518**	8"	18"	585 Lbs.
CBISSAV202521**	11"	21"	615 Lbs.
CBISSAV202524**	14"	24"	644 Lbs.

**Note: Spring configuration must be added to part number at time of order - See current price guide

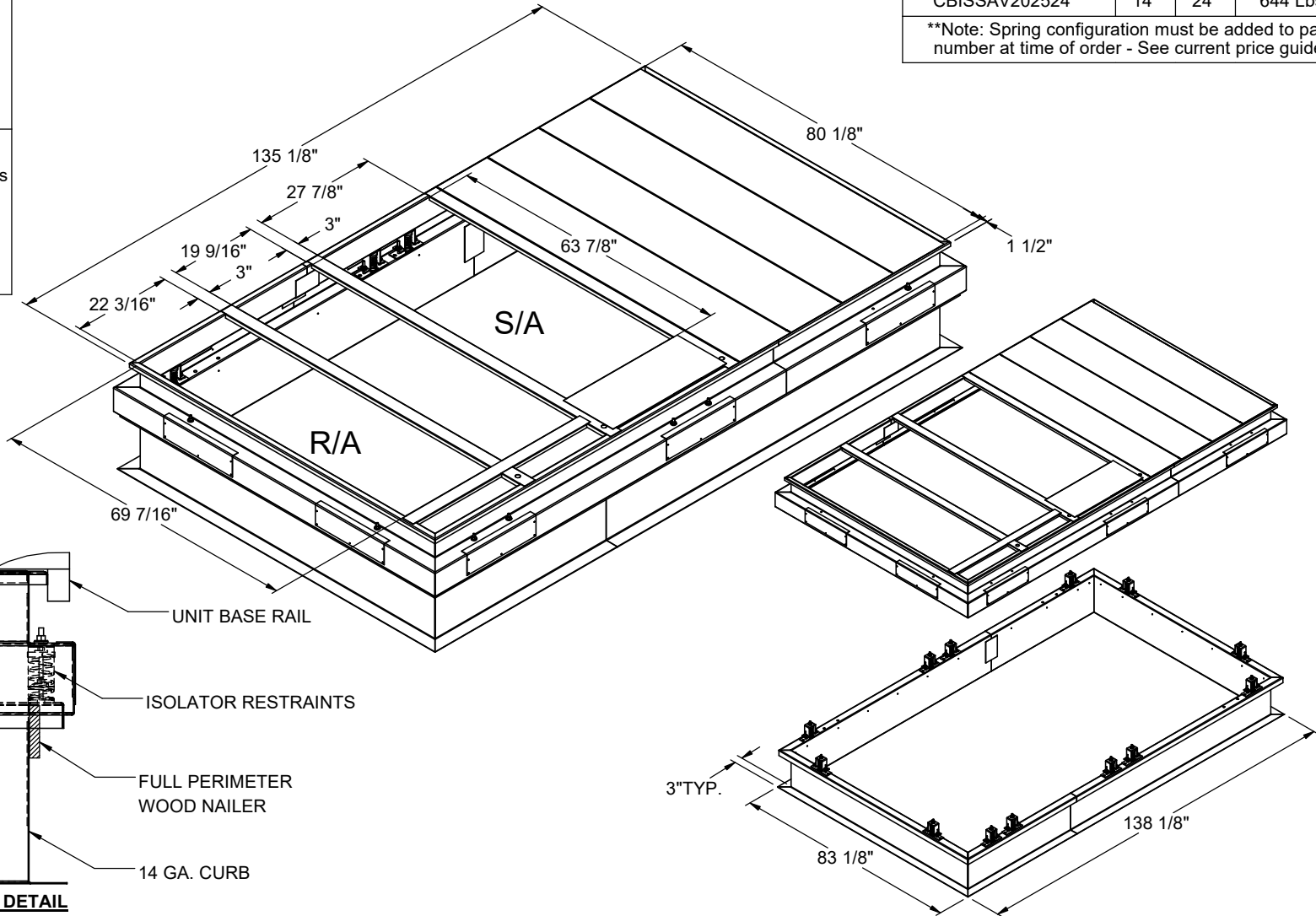

3847 WABASH DRIVE
MIRA LOMA, CA 91752

PHONE (951) 685-1101
FAX (619) 872-9799

SUBMITTED TO: _____
 COMPANY: _____
 JOB NAME: _____
 EQUIPMENT: _____
 NOTES: _____

FORM NO:
CBIS-123

DATE:
1/27/2025

PART NUMBER:
CBISSAV2025 SERIES

REV:
1

DRAWN BY:
CNG