

For wood, concrete and steel attachment see Roof Anchorage Detail, Form No. CB-62.

VIBRATION ISOLATION ROOF CURBS FOR YORK UNITS

PROVENT P/N	A	B	EST. WEIGHT
CBISLXL18*	8"	18"	175 Lbs.
CBISLXL21**	11"	21"	194 Lbs.
CBISLXL24**	14"	24"	211 Lbs.
*Upper Shell Weight			100 Lbs.

PG3E, PC3E, PCG4B, PCE4B 48-60
PCG6B, PCE6B, PHE4/6B, PHG4/6B 36-60

FEATURES

- Roof curbs sides and ends are galvanized steel.
- Fully welded construction.
- Gasketing package provided.
- Heat treated wood nailer provided.
- Insulated deck pans provided.
- Pitched curbs and taller curbs are available.

NOTES

- Attach ductwork to roof curb. Flanges of duct rest on top of the curb, Support ductwork below the curb.

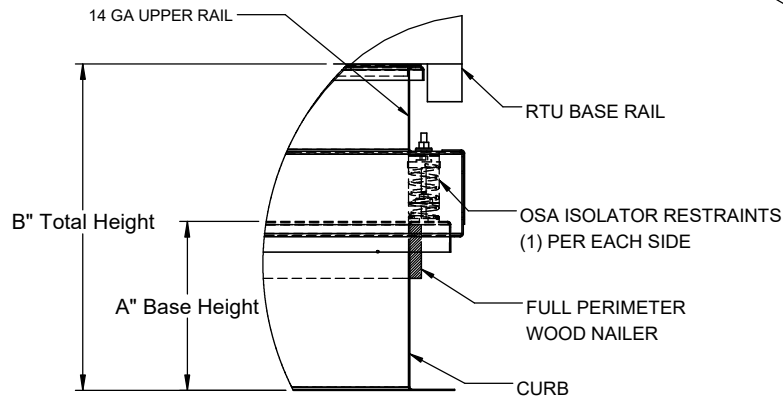
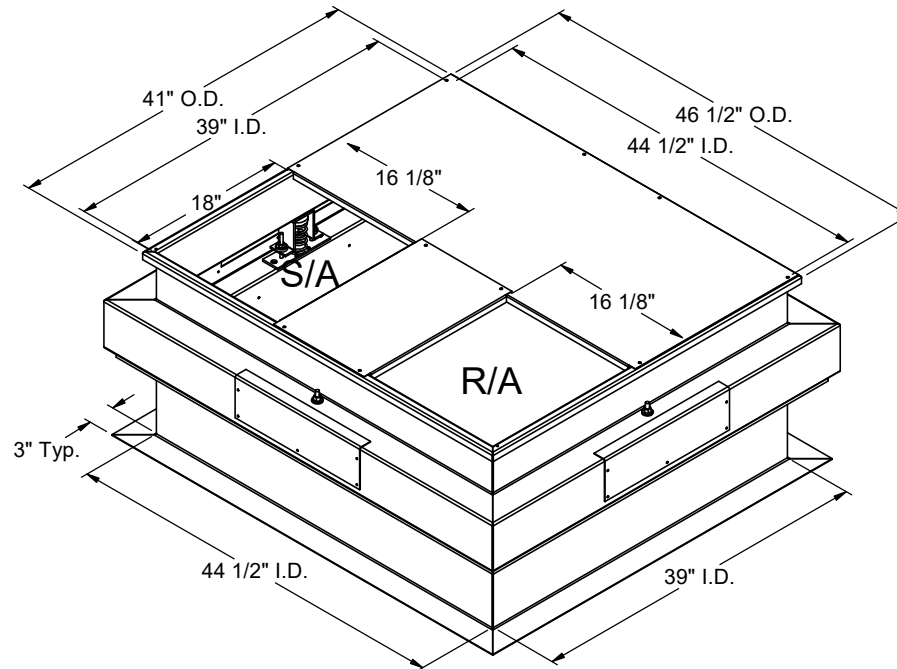

PROFILE DETAIL

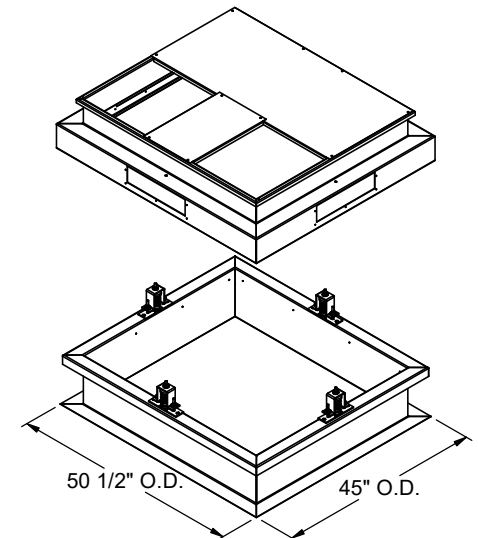

EXPLODED DETAIL



3847 WABASH DRIVE
MIRA LOMA, CA 91752

PHONE (951) 685-1101
FAX (619) 872-9799

SUBMITTED TO: _____
COMPANY: _____
JOB NAME: _____
EQUIPMENT: _____
NOTES: _____

FORM NO:
CBIS-120

PART NUMBER:
CBISLXL SERIES

DATE:
1/13/2025

REV:
2

DRAWN BY:
CNG