

VIBRATION ISOLATION ROOF CURBS FOR YORK SMALL SUNLINE 3-6 TON UNITS

For wood, concrete and steel attachment, see Roof Anchorage Detail Form No. CB-62.

PROVENT P/N	A	B	EST. WEIGHT
CBISSUN367218**	8"	18"	178 Lbs.
CBISSUN367221**	11"	21"	198 Lbs.
CBISSUN367224**	14"	24"	218 Lbs.

**Note: Spring configuration must be added to part number at time of order. See Price Guide for details.

Weight of upper portion supported by spring isolators= 111 Lbs.

ZR, XN, XP, WN 036-060,
ZE, ZF, KE 036-072

FEATURES

- Roof curbs sides and ends are 16 ga.
- Fully welded construction.
- Gasketing package provided.
- Heat treated wood nailer provided.
- insulated deck pans provided.
- Pitched curbs and taller curbs are available.

NOTES

- Attach ductwork to roof curb. Flanges of duct rest on top of the curb, Support ductwork below the curb.

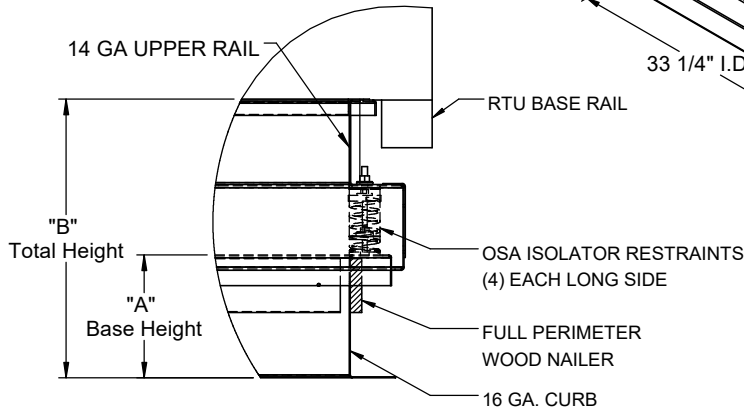
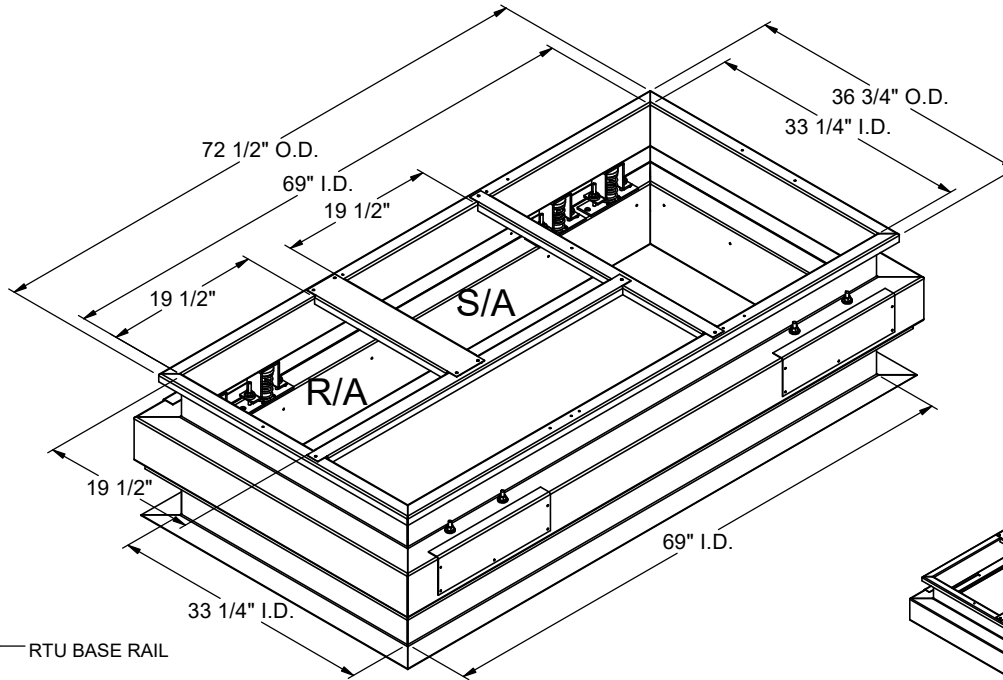

PROFILE DETAIL

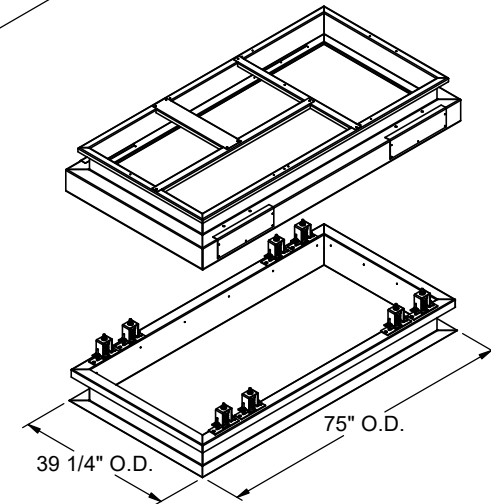

EXPLODED DETAIL



**3847 WABASH DRIVE
MIRA LOMA, CA 91752**

**PHONE (951) 685-1101
FAX (619) 872-9799**

SUBMITTED TO: _____
 COMPANY: _____
 JOB NAME: _____
 EQUIPMENT: _____
 NOTES: _____

FORM NO:
CBIS-102

DATE:
1/10/2025

PART NUMBER:
CBISSUN3672 SERIES

REV:
7

DRAWN BY:
CNG