

Approved By _____ Date: _____

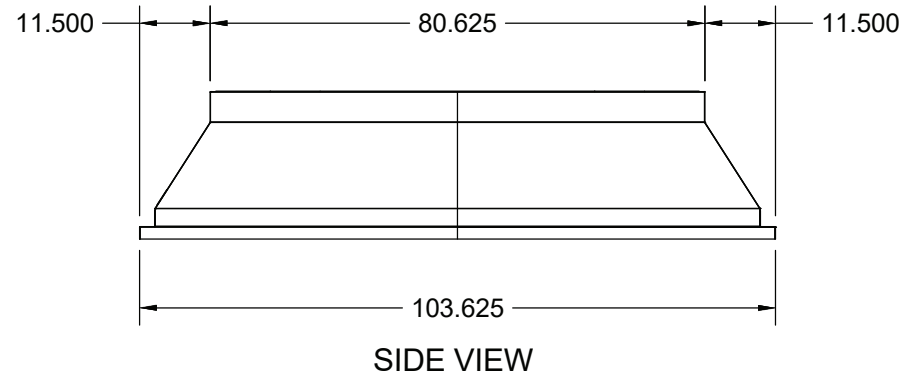
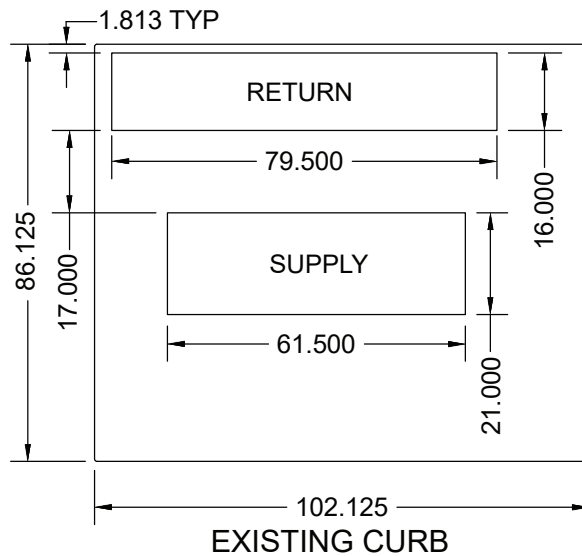
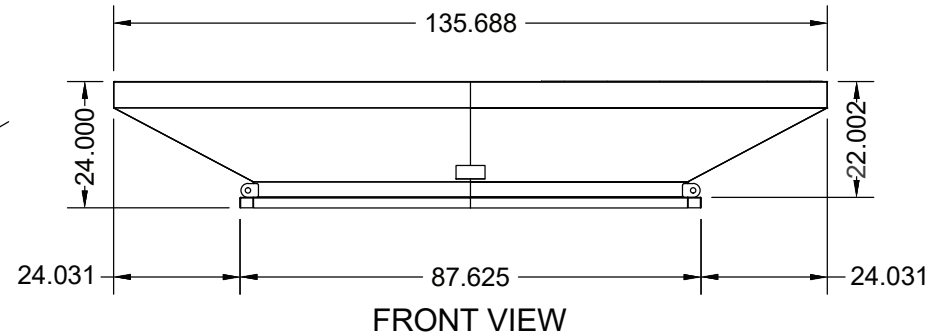
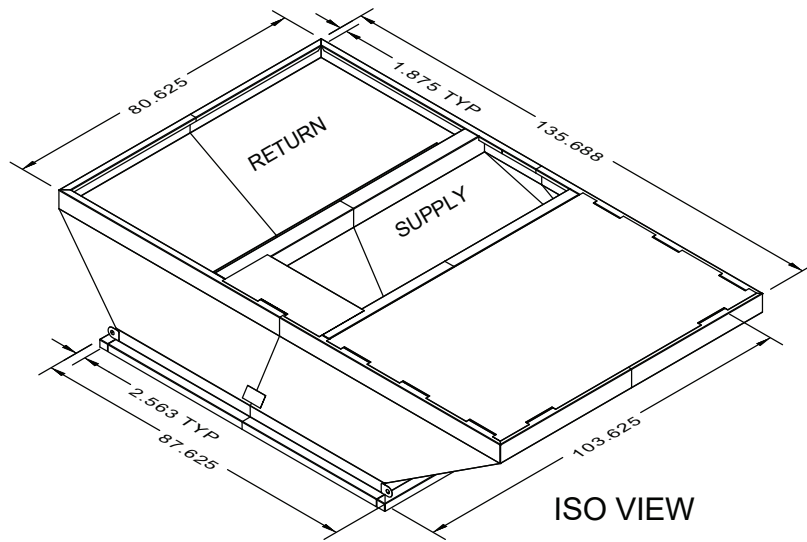

RRS ROOFTOP SYSTEMS

1625 Diplomat Drive, Carrollton, Texas 75006-6848
Phone (972) 247-7447 (800) 552-4822
Fax (972) 243-0940

Notes:

1. Fully welded G90 galvanized construction
2. Supply and Return plenums fully insulated
3. Gaskets shipped with adapter
4. RRS reserves the right to change layout without notification.
5. If a curb adapter is needed in a different configuration, notify RRS prior to placing an order.
6. Curb Adapters up to 12.5 tons designed for less than .35" Total Static Pressure.
7. Curb Adapters from 15-25 tons designed for less than .625" Total Static Pressure.

Curb Adapter for York International
Old Unit: LGA / LCA 300H-360
New Unit: AV20-25, AW13-15, AH, AL18-20, HV15-20

- Verify existing curb dimensions
- Verify supply and return ducts.
- Document variations
- Contact RRS for all concerns and drawing verification.

Part No: 30-290-5575
Duct Type: Non-Concentric
Weight: 533 lbs
Static Pressure: N/A
Form#: 305575Y
Date: April 28, 2020
Supersedes: None