

Approved By \_\_\_\_\_ Date: \_\_\_\_\_

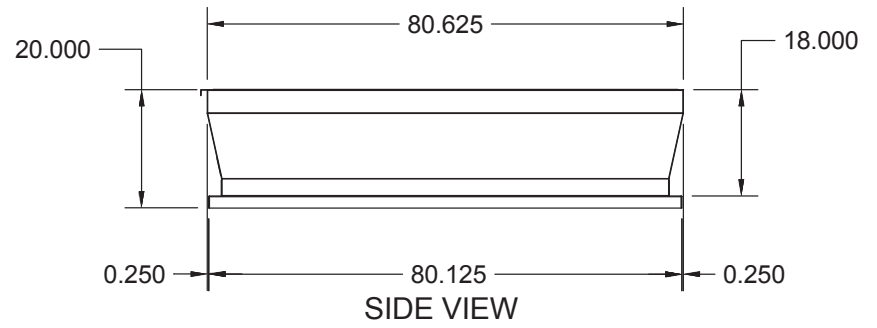
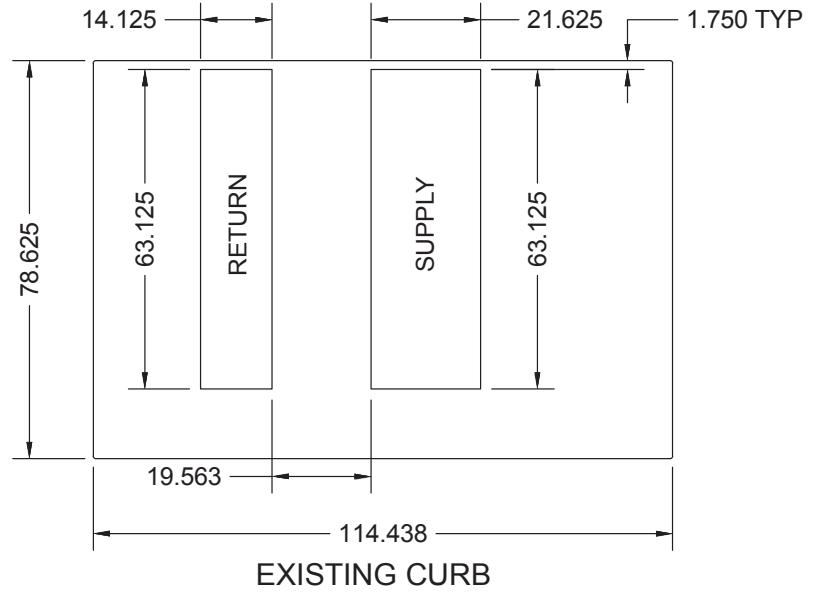
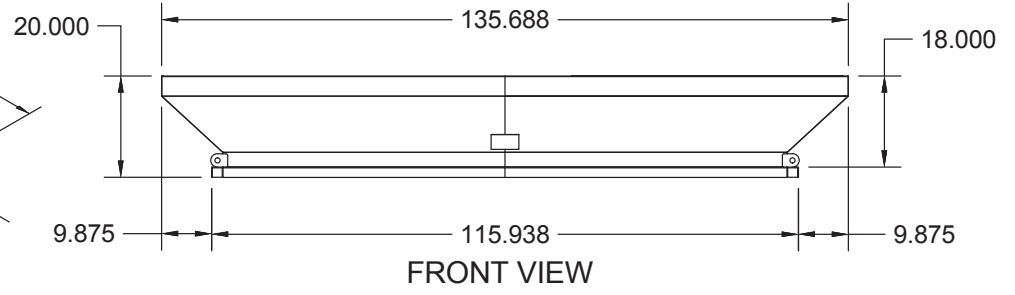
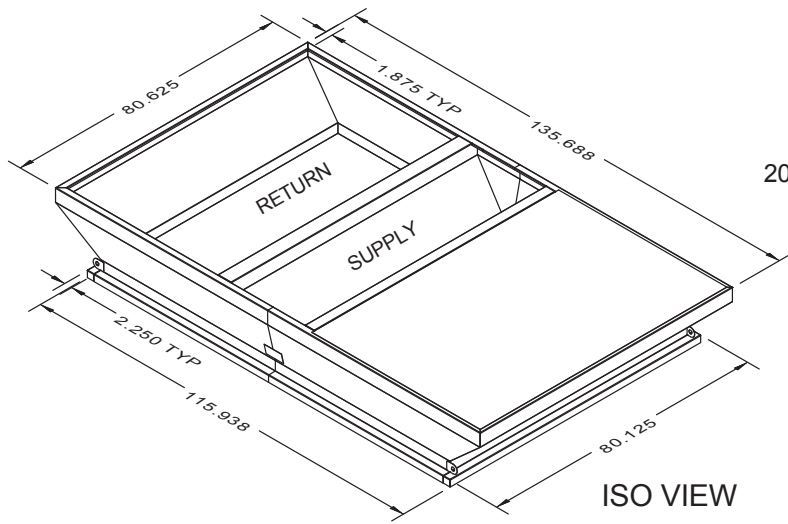

**RRS** ROOFTOP SYSTEMS

1625 Diplomat Drive, Carrollton, Texas 75006-6848  
 Phone (972) 247-7447 (800) 552-4822  
 Fax (972) 243-0940

- Notes:
1. Fully welded G90 galvanized construction
  2. Supply and Return plenums fully insulated
  3. Gaskets shipped with adapter
  4. RRS reserves the right to change layout without notification.
  5. If a curb adapter is needed in a different configuration, notify RRS prior to placing an order.
  6. Curb Adapters up to 12.5 tons designed for less than .35" Total Static Pressure.
  7. Curb Adapters from 15-25 tons designed for less than .625" Total Static Pressure.

**Curb Adapter for York**  
**Old Unit: 48 HJ / PG 020-028, HG 014-028**  
**New Unit: AV20-25, AW13-15, AH, AL18-20, HV15-20**

<ul style="list-style-type: none"> <li>• Verify existing curb dimensions</li> <li>• Verify supply and return ducts.</li> <li>• Document variations</li> <li>• Contact RRS for all concerns and drawing verification.</li> </ul>	Part No: 30-290-5532
	Duct Type: Non-Concentric
	Weight: 464 lbs
	Static Pressure: N/A
	Form#: 305532
	Date: May 29, 2019
Supersedes: None	