



INSTALLATION INSTRUCTIONS  
 PEHCPRL Series Horizontal Power Exhaust  
 for  
 York PRESTIGE for ZX 08-014; ZY 07-12

**Before Starting Installation**

Only qualified HVAC service personnel should install, troubleshoot, repair or service HVAC and related HVAC equipment.

**Step 1:**

Verify all unit parts in box .

- 1 ea. - Power Exhaust Assembly
- 1 ea. - Hardware Bag:
- 8 ea. - Self- Tapping- #10 16 x 1/2 Screws

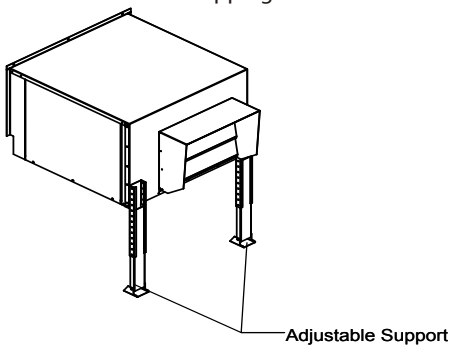

Figure 1

**⚠ WARNING**

Electric shock hazard. Can cause injury or death. Before attempting to perform any service or maintenance, turn the electrical power to unit OFF at disconnect switch(es).

**Step 2:**

Remove the control access panel. Remove the blower access panel. Keep all screws for later use. See Figure 2.

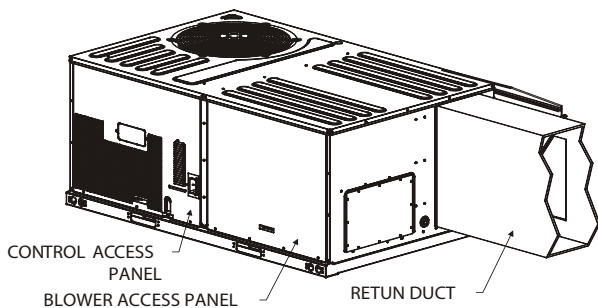

Figure 2

**Step 3:**

Remove the panel over the economizer hood (models ZX\*09, ZX \*12, ZX\*14, ZY\*08, ZY\*09 and ZY\*12 only). Remove the horizontal flow economizer hood. See Figure 3.

Important

If supplied with power exhaust option, power exhaust power (Molex) connection is located on economizer next to its power connection. Make sure to plug in power exhaust when connecting economizer power in Step 3 of instructions below.

**Step 4:**

Cut hole in return duct 29 5/8" wide x 17" tall where power exhaust is to be installed. See Figure 3.

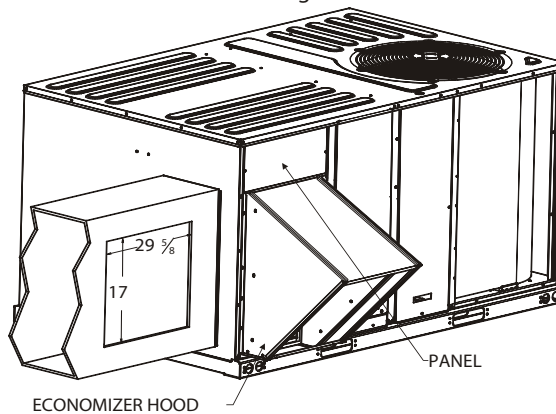

Figure 3

**Step 5:**

Position the power exhaust assembly close to the opening cut in the return duct. Route the power and control harnesses thru the hole cut in the return duct to the return area of the economizer. See Figure 4.

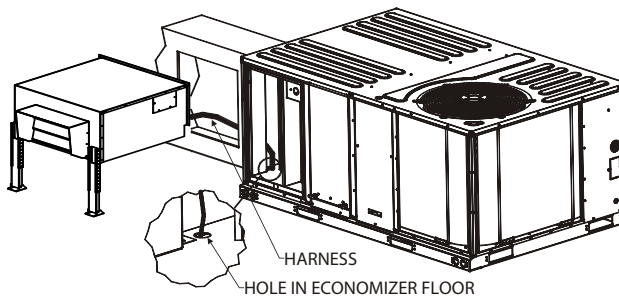

Figure 4

**Step 6:**

Use self-tapping screws provided to mount the power exhaust assembly over the hole cut into the return duct opening. After the power exhaust assembly is mounted to the return duct, pull any remaining slack in the power exhaust power and control harnesses thru the return duct into the return area of the economizer.

Locate the power exhaust control harness with wire numbers 843 (grey) and 844 (brown). Connect this harness to the location marked EX-FAN/ COM on the economizer controller. Secure this harness to avoid damage during normal damper operation. See wiring diagram for details.

Step 7:

Locate high voltage harness with black, blue and yellow wires (NOTE - yellow wire is not included with single phase power exhaust assemblies). Route the power harness thru the unit and along the existing harnesses in the unit back to the unit control panel as illustrated in Figure 5. Secure the power exhaust power harness to the existing harnesses throughout the unit with (field supplied) wire ties.

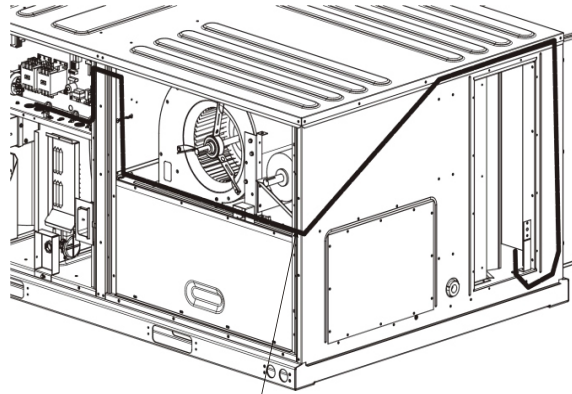

Figure 5

Step 8:

Connect the power harness to the line side of contactor M1 (see unit control panel component map for location of contactor M1). Remove and reconnect existing wires as necessary using the pigtailed provided with the power exhaust power wires. Connect the black wire to terminal 1 on contactor M1, the blue wire to terminal 2 on contactor M1 and the yellow wire to terminal 3 on contactor M1 (Yellow wire only on 3 phase units). See wiring diagram.

Step 9:

Install control access panel and blower access panel using screws originally used to hold the panels in place. See Figure 6.

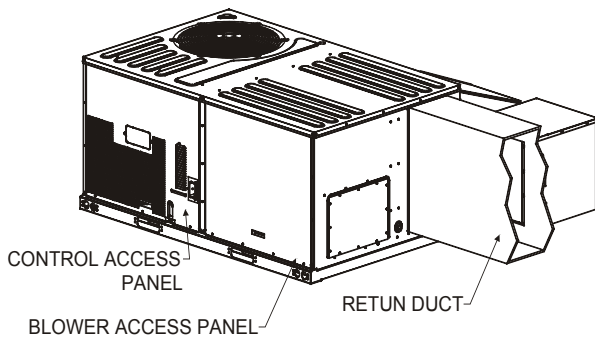

Figure 6

Step 10:

Install the economizer hood. Install the panel over the economizer hood (models ZX\*07, ZY\*05 and ZY\*06 only). See Figure 7.

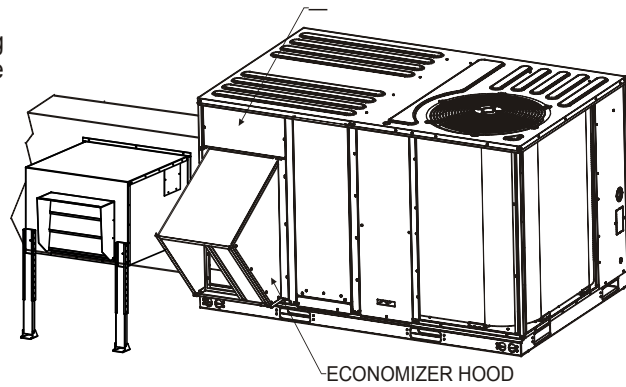

Figure 7

Step 11:

Reconnect power to the unit - follow all safety instructions, rules and codes.

See unit Installation, Operation and Maintenance manual for instructions to verify the unit controller recognizes the installation of the power exhaust.

Note: Once the unit is operating properly, seal any open joints, holes, or seams with silicone caulking (field supplied), to make the power exhaust completely air and water tight.

## ILL. 1 - Constant Volume Power Exhaust Wiring (3 Phase)

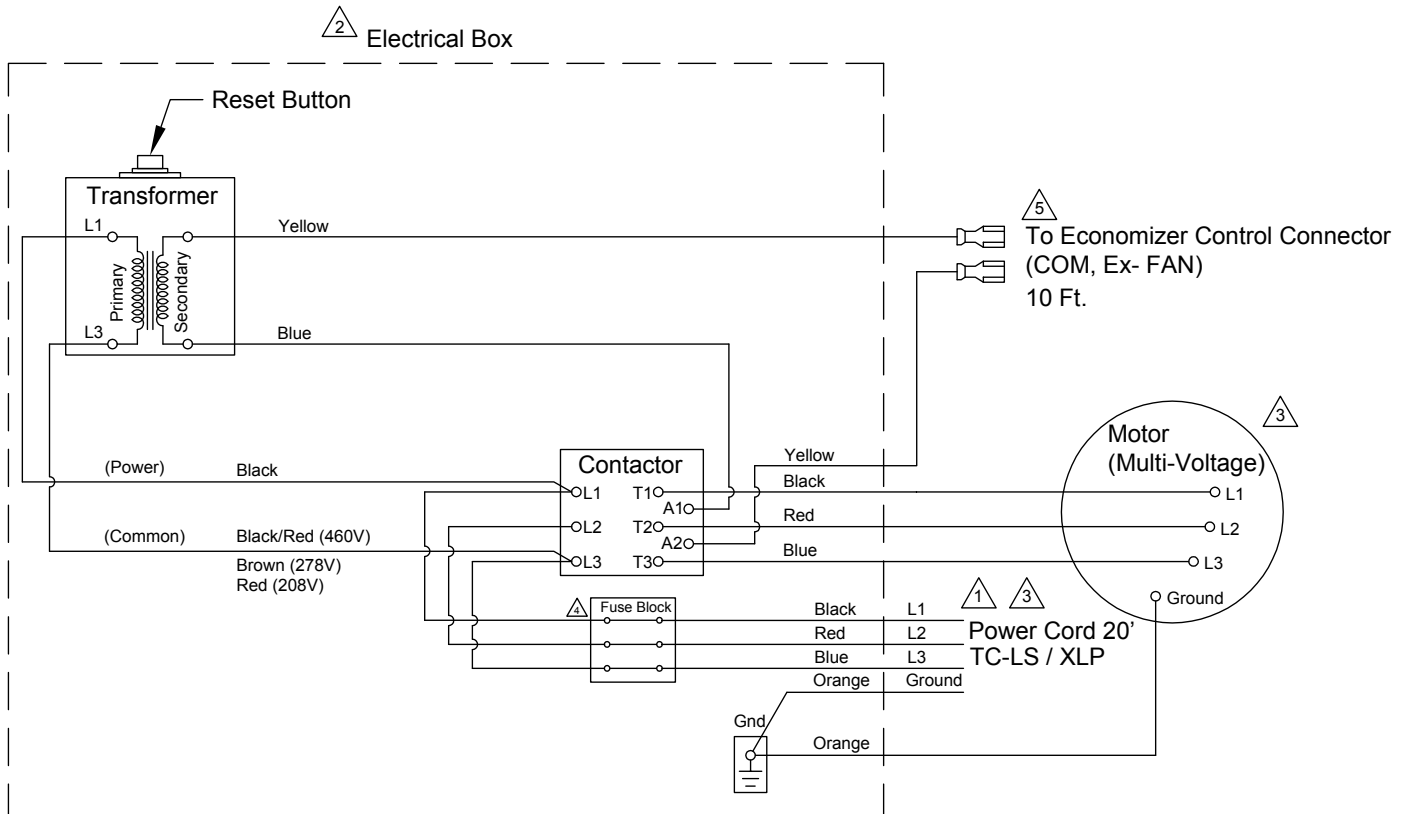

**1** Power Supply. Provide disconnect means and circuit protection as required. See power exhaust name plate for electrical ratings. If local codes allow connecting to the HVAC unit power, make sure the disconnect and incoming wiring are sized to handle the load of both the HVAC unit and the power exhaust.

To determine MCA with power exhaust:  $\text{New MCA} = \text{MCA of Unit Only} + \text{MCA of Power Exhaust}$

**2** Transformer, contactor and fuses are to be in a NEMA type electrical enclosure.

**3** For voltage, refer to label on exterior of power exhaust cabinet.

**4** 3 amp KTK fuses (460V-3PH). 7 amp KTK fuses (230V-3PH). 10, 15 amp KTK fuses (230-1PH)

**5** Field connection to Economizer control terminal connector.

Example: With a unit that has MCA=22.5 amps and MOCP=30 amps,

New MCA = 22.5 amps + 3 amps (example for power exhaust) = 25.5 amps

If New MCA is less than MOCP for the HVAC unit, you can tie the power wire to the HVAC contactor terminal strip, if local code allows. Make sure tap off terminal block is capable for handling more than one unit.

If new MCA is greater than MOCP or local code requires, you must run power wire for the power exhaust to an external disconnect. Make sure the disconnect is sized properly for the power from the power exhaust as well as the HVAC unit.

## ILL. 2 - Constant Volume Power Exhaust Wiring (1 Phase)

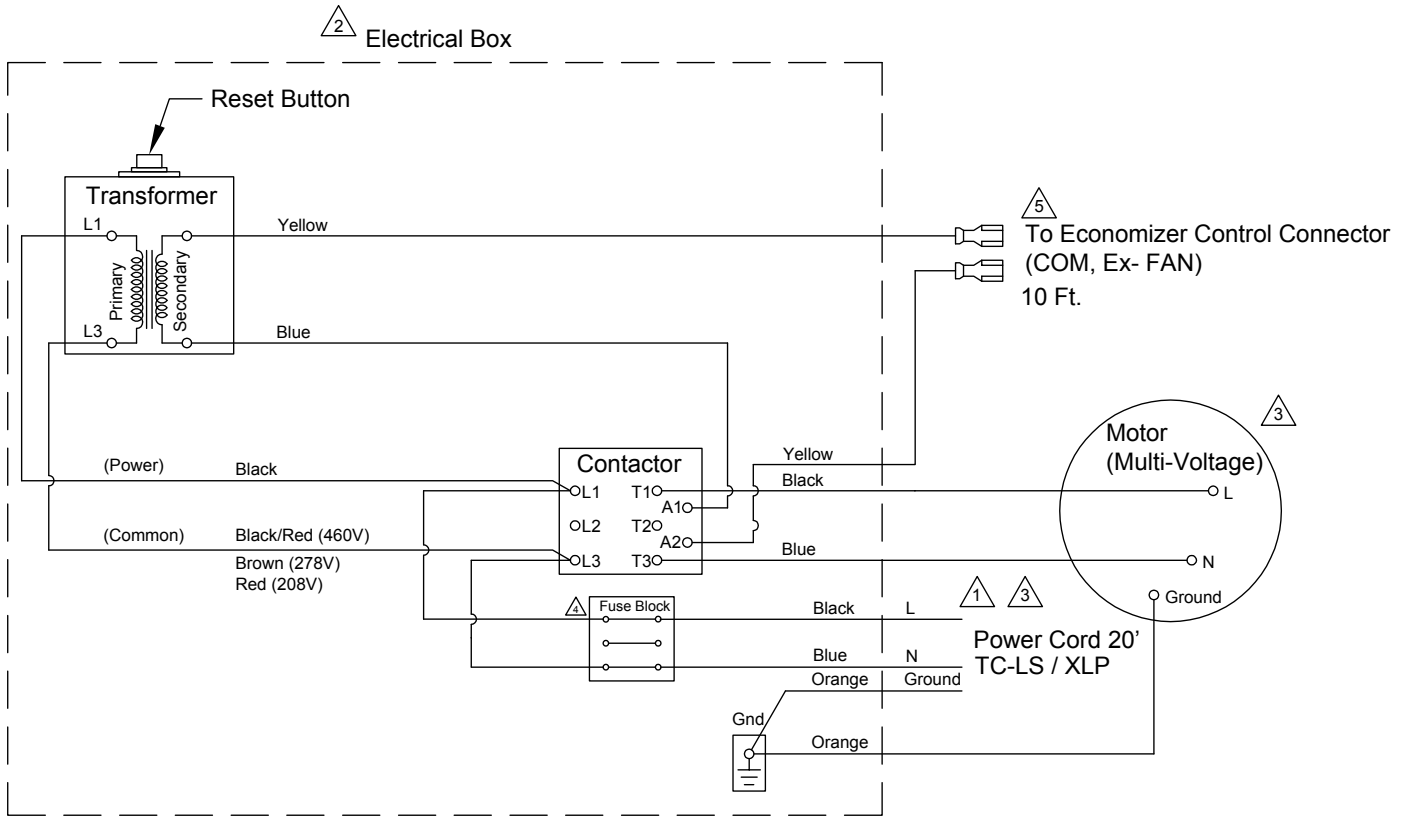

1 Power Supply. Provide disconnect means and circuit protection as required. See power exhaust name plate for electrical ratings. If local codes allow connecting to the HVAC unit power, make sure the disconnect and incoming wiring are sized to handle the load of both the HVAC unit and the power exhaust.

To determine MCA with power exhaust:  $\text{New MCA} = \text{MCA of Unit Only} + \text{MCA of Power Exhaust}$

2 Transformer, contactor and fuses are to be in a NEMA type electrical enclosure.

3 For voltage, refer to label on exterior of power exhaust cabinet.

4 3 amp KTK fuses (460V-3PH). 7 amp KTK fuses (230V-3PH). 10, 15 amp KTK fuses (230-1PH)

5 Field connection to Economizer control terminal connector.

Example: With a unit that has  $\text{MCA}=22.5$  amps and  $\text{MOCP}=30$  amps,

$\text{New MCA} = 22.5$  amps + 3 amps (example for power exhaust) = 25.5 amps

If New MCA is less than MOCP for the HVAC unit, you can tie the power wire to the HVAC unit contactor terminal strip, if local code allows. Make sure tap off terminal block is capable for handling more than one unit.

If new MCA is greater than MOCP or local code requires, you must run power wire for the power exhaust to an external disconnect. Make sure the disconnect is sized properly for the power from the power exhaust as well as the HVAC unit.

### ILL. 3 - Modulating Power Exhaust Option Wiring ( 3 Phase)

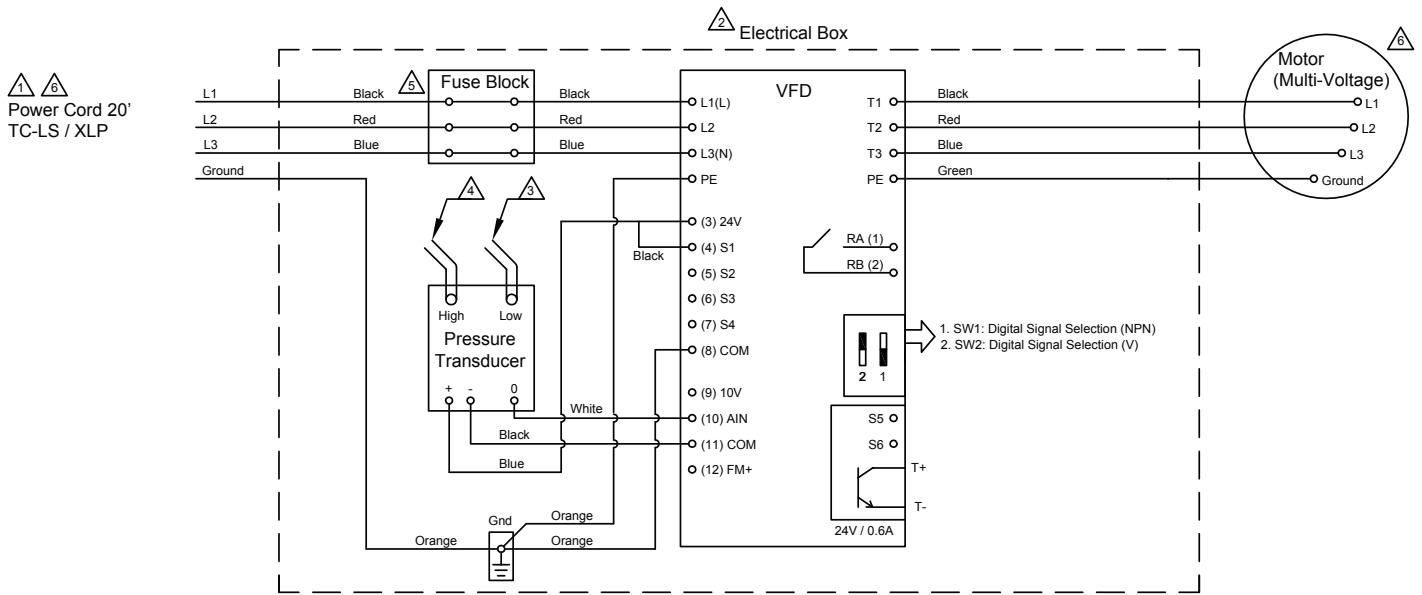

### ILL. 4 - Modulating Power Exhaust Option Wiring ( 1 Phase)

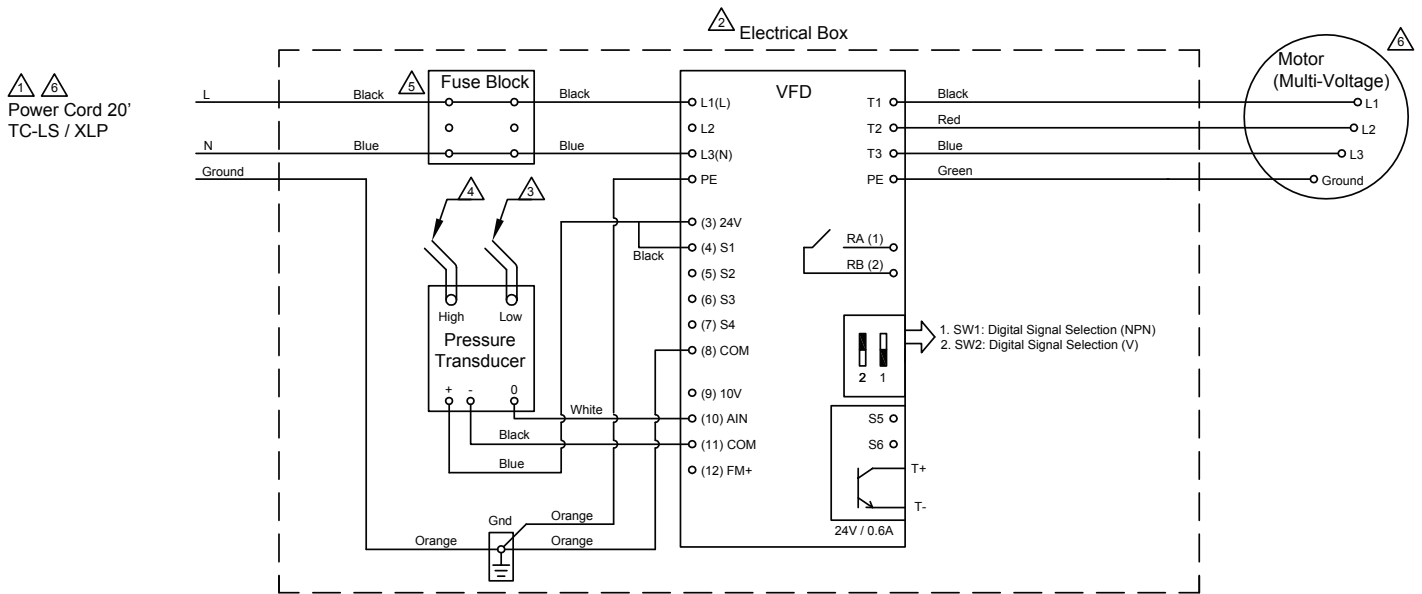

⚠ Power Supply. Provide disconnect means and circuit protection as required. See power exhaust name plate for electrical ratings. If local codes allow connecting to the HVAC unit power, make sure the disconnect and incoming wiring are sized to handle the load of both the HVAC unit and the power exhaust.

To determine MCA with power exhaust:  $\text{New MCA} = \text{MCA of Unit Only} + \text{MCA of Power Exhaust}$

⚠ Transformer, contactor and fuses to be in a NEMA type electrical enclosure.

⚠ Factory mounted 3/16" low pressure tubing.

⚠ 25 feet of 3/16" high pressure tubing and connection port provided for field mounting in conditioned space. Architectural finishing field provided. (Follow local codes.)

⚠ 3 amp KTK fuses (460V-3PH). 7 amp KTK fuses (230V-3PH). 10, 15 amp KTK fuses (230-1PH)

⚠ For voltage, refer to label on exterior of power exhaust cabinet.

If the Power Exhaust is installed with the Simplicity Smart Equipment (SSE) board, please change the following fan type settings:

Details <enter>

Control <enter>

Power Ex <enter>

Ex FType <enter>

"select" Non- Modulating <enter>

To change the setpoints for "ON" and "OFF"

EconDmpPos- FanOn <60% default>

EconDmpPos- FanOff <20% default>

The motor/blower is connected to a motor controller (VFD) that varies the speed to maintain an acceptable conditioned space pressure. The power exhaust system includes a low pressure transducer that compares room pressure to atmospheric. This transducer sends a signal to the motor controller (VFD) which varies the motor frequency in order to provide pressure relief.

1. Install 3/16" pressure tubing as per wiring diagram making sure it is not located near any S/A or R/A diffuser or door.
2. The VFD is factory preprogrammed to accept the 0 to 10 VDC signal through the pressure transducer.

Table 1 - Pressure vs. VFD Frequency

Transducer Output Signal (VDC)	Conditioned Space Pressure (Inch W.G.)	VFD Setting (Hz)
0	0	0
1	0.01	10
2	0.02	20
3	0.03	30
4	0.04	40
5	0.05	50
6	0.06	60
7	0.07	70
8	0.08	80
9	0.09	90
10	0.10	100

VFD is factory set at 0.04 inches w.g. To change setting, press and hold "OK" to access the programming menu; up/down to display P-45, hit "OK" move arrows up/down to set desired frequency that determines pressure requirement, then press "OK" to save parameter.

**AIR ECONOMIZER CONTROLS ACCEPTANCE**

CEC-NRCA-MCH-05-A (Revised 06/14)

CALIFORNIA ENERGY COMMISSION



CERTIFICATE OF ACCEPTANCE		NRCA-MCH-05-A
Air Economizer Controls Acceptance		(Page 1 of 3)
Project Name:	Enforcement Agency:	Permit Number:
Project Address:	City:	Zip Code:
System Name or Identification/Tag:	System Location or Area Served:	

Note: Submit one Certificate of Acceptance for each system that must demonstrate compliance.

Enforcement Agency Use: Checked by/Date

<p><b>A. Construction Inspection</b></p> <p>1. Supporting documentation needed to perform test includes:</p> <ol style="list-style-type: none"> <li>2013 Building Energy Efficiency Standards Nonresidential Compliance Manual (NA7.5.4 Air Economizer Controls Acceptance At - Glance).</li> <li>2013 Building Energy Efficiency Standards.</li> </ol> <p>2. Instrumentation to perform test includes:</p> <ol style="list-style-type: none"> <li>Hand-held temperature probe Calibration Date: _____ (must be within last year)</li> <li>Device capable of calculating enthalpy Calibration Date: _____ (must be within last year)</li> <li>1.2 k Ohm Resistor ( when specified by the manufacturer)</li> </ol> <p>3. Installation: (all of the following boxes should be checked)</p> <ul style="list-style-type: none"> <li><input type="checkbox"/> Economizer high limit shutoff control complies with Table 140.4-B found in the 2013 Building Energy Efficiency Standards Section 140.4(e)3.</li> <li><input type="checkbox"/> Economizer reliability features are present per 2013 Building Energy Efficiency Standards Section 140.4(e)4: <ol style="list-style-type: none"> <li>5-year manufacturer warranty of economizer assembly</li> <li>Provide a product specification sheet proving capability of at least 60,000 actuations</li> <li>Provide a product specification sheet proving compliance with AMCA Standard 500 damper leakage at 10 cfm/sf at 1.0 in w.g. A product specification sheet showing the manufacturer's results after following the testing procedures of AMCA Standard 500 or AMCA certification by a third party under AMCA Publication 511 can be used to satisfy this requirement (Class 1A, 1, and 2 are acceptable).</li> <li>If the high limit setpoint is fixed dry-bulb or fixed enthalpy + fixed dry-bulb then the control shall have an adjustable setpoint</li> <li>Outdoor air, return air, mixed air, and supply air sensors shall be calibrated as follows: <ol style="list-style-type: none"> <li>Drybulb and wetbulb temperatures accurate to <math>\pm 2^{\circ}\text{F}</math> over the range of 40°F to 80°F</li> <li>Enthalpy accurate to <math>\pm 3</math> Btu/lb over the range of 20 Btu/lb to 36 Btu/lb</li> <li>Relative humidity (RH) accurate to <math>\pm 5\%</math> over the range of 20% to 80% RH</li> </ol> </li> <li>Check that the sensor performance curve(s) is provided by the factory and sensor output values measured during sensor calibration are plotted on the performance curve(s)</li> <li>Sensors used for high limit control shall be located to prevent false readings, including but not limited to being properly shielded from direct sunlight.</li> </ol> </li> <li><input type="checkbox"/> Unitary systems with an economizer have control systems, including two-stage or electronic thermostats, that cycle compressors off when economizers can provide partial cooling</li> <li><input type="checkbox"/> System has return fan speed control, relief dampers, or dedicated relief fans to prevent building over pressurization in full economizer mode.</li> <li><input type="checkbox"/> For systems with DDC controls, sensor used for economizer lockout has been factory or field calibrated.</li> <li><input type="checkbox"/> For systems with non-DDC controls, manufacturer's startup and testing procedures have been applied.</li> </ul>
---

# AIR ECONOMIZER CONTROLS ACCEPTANCE

CEC-NRCA-MCH-05-A (Revised 06/14)

CALIFORNIA ENERGY COMMISSION



<b>CERTIFICATE OF ACCEPTANCE</b>		<b>NRCA-MCH-05-A</b>
Air Economizer Controls Acceptance		(Page 2 of 3)
Project Name:	Enforcement Agency:	Permit Number:
Project Address:	City:	Zip Code:
System Name or Identification/Tag:	System Location or Area Served:	

B. Functional Testing	Results
Step 1: Disable demand control ventilation systems (if applicable)	
Step 2: Enable the economizer and simulate a cooling demand large enough to drive the economizer fully open. Verify the following:	
a. Economizer damper modulates 100% open.	Y / N
b. Return air damper modulates 100% closed.	Y / N
c. For systems that meet the criteria of 2013 Building Energy Efficiency Standards Section 140.4(e)1, verify that the economizer remains 100% open with the use of mechanical cooling. This occurs when the cooling demand can no longer be met by the economizer alone.	Y / N
d. All applicable fans and dampers operate as intended to maintain building pressure.	Y / N
e. The unit heating is disabled (if applicable).	Y / N / NA
Step 3: Disable the economizer and simulate a cooling demand. Verify the following:	
a. Economizer damper closes to its minimum position.	Y / N
b. All applicable fans and dampers operate as intended to maintain building pressure.	Y / N
c. The unit heating is disabled (if applicable).	Y / N / NA
Step 4: If the unit is equipped with heating, simulate a heating demand and enable the economizer. Verify the following:	
a. Economizer damper closes to its minimum position.	Y / N / NA
b. Return air damper opens.	Y / N / NA
Step 5: Turn off the unit and verify the following:	
a. Economizer damper closes completely.	Y / N
Step 6: System returned to initial operating conditions	Y / N

C. Testing Results	PASS / FAIL
Step 2: Simulate cooling load and enable the economizer (all answers are Y).	
Step 3: Simulate cooling load and disable the economizer (all answers are Y).	
Step 4: Simulate heating demand and enable the economizer (all answers are Y).	
Step 5: Turn off the unit (all answers are Y).	

D.	Evaluation :	
<input type="checkbox"/>	PASS: All Construction Inspection responses are complete and all Testing Results responses are "Pass"	

Notes:



**AIR ECONOMIZER CONTROLS ACCEPTANCE**

CEC-NRCA-MCH-05-A (Revised 06/14)

CALIFORNIA ENERGY COMMISSION



CERTIFICATE OF ACCEPTANCE		NRCA-MCH-05-A
Air Economizer Controls Acceptance		(Page 3 of 3)
Project Name:	Enforcement Agency:	Permit Number:
Project Address:	City:	Zip Code:
System Name or Identification/Tag:	System Location or Area Served:	

**DOCUMENTATION AUTHOR'S DECLARATION STATEMENT**

1. I certify that this Certificate of Acceptance documentation is accurate and complete.

Documentation Author Name:	Documentation Author Signature:
Documentation Author Company Name:	Date Signed:
Address:	ATT Certification Identification (if applicable):
City/State/Zip:	Phone:

**FIELD TECHNICIAN'S DECLARATION STATEMENT**

I certify the following under penalty of perjury, under the laws of the State of California:

1. The information provided on this Certificate of Acceptance is true and correct.
2. I am the person who performed the acceptance verification reported on this Certificate of Acceptance (Field Technician).
3. The construction or installation identified on this Certificate of Acceptance complies with the applicable acceptance requirements indicated in the plans and specifications approved by the enforcement agency, and conforms to the applicable acceptance requirements and procedures specified in Reference Nonresidential Appendix NA7.
4. I have confirmed that the Certificate(s) of Installation for the construction or installation identified on this Certificate of Acceptance has been completed and signed by the responsible builder/installer and has been posted or made available with the building permit(s) issued for the building.

Field Technician Name:	Field Technician Signature:	
Field Technician Company Name:	Position with Company (Title):	
Address:	ATT Certification Identification (if applicable):	
City/State/Zip:	Phone:	Date Signed:

**RESPONSIBLE PERSON'S DECLARATION STATEMENT**

I certify the following under penalty of perjury, under the laws of the State of California:

1. I am the Field Technician, or the Field Technician is acting on my behalf as my employee or my agent and I have reviewed the information provided on this Certificate of Acceptance.
2. I am eligible under Division 3 of the Business and Professions Code in the applicable classification to accept responsibility for the system design, construction or installation of features, materials, components, or manufactured devices for the scope of work identified on this Certificate of Acceptance and attest to the declarations in this statement (responsible acceptance person).
3. The information provided on this Certificate of Acceptance substantiates that the construction or installation identified on this Certificate of Acceptance complies with the acceptance requirements indicated in the plans and specifications approved by the enforcement agency, and conforms to the applicable acceptance requirements and procedures specified in Reference Nonresidential Appendix NA7.
4. I have confirmed that the Certificate(s) of Installation for the construction or installation identified on this Certificate of Acceptance has been completed and is posted or made available with the building permit(s) issued for the building.
5. I will ensure that a completed, signed copy of this Certificate of Acceptance shall be posted, or made available with the building permit(s) issued for the building, and made available to the enforcement agency for all applicable inspections. I understand that a signed copy of this Certificate of Acceptance is required to be included with the documentation the builder provides to the building owner at occupancy.

Responsible Acceptance Person Name:	Responsible Acceptance Person Signature:	
Responsible Acceptance Person Company Name:	Position with Company (Title):	
Address:	CSLB License:	
City/State/Zip:	Phone:	Date Signed: