



# INSTALLATION INSTRUCTIONS

## PEDCSAV Series Power Exhaust for York Sun Choice 15-20 Ton Units

### Before Starting Installation

#### Warning

Severe injury can result from incorrect servicing. Only qualified HVAC service personnel should install, trouble-shoot, repair or service HVAC and related HVAC equipment.

Always disconnect power before servicing. Please note some installation configurations may have more than one disconnect.

#### Important

Always follow all local building electrical codes.

#### PEDCSAV1520

Voltage	ProVent P/N	External Static (in. W.G.)	FLA	HP
230/3Ph	PEDCSAV152025CS PEDCSAV152025MS	8,000 cfm	11.2	4 Hp Total (Qty. 2: 2 Hp)
460/3Ph	PEDCSAV152046CS PEDCSAV152046MS		5.6	

PARTS INCLUDED	STANDARD OUTPUT QTY.
#12 x 3/4 Sheet Metal Screw	40
Adjustable Unit Supports	2
3/16" Dia x 25' Pressure Tubing (w/Modulating Option Only)	1
Pressure Connection Port (w/Modulating Option Only)	1

### Installation Instructions

1. Mount the power exhaust unit on the end side of the return air compartment of the RTU. Install adjustable unit supports and attach to RTU using #12 screws provided. (ILL. 1)
2. The line voltage can be access from the access panel. See wiring diagram notes and follow all electrical codes for connection. (ILL. 2 & ILL. 3)
3. For modulating option, feed the pressure tubing located in the power exhaust cabinet to the conditioned space in the building. For lengths longer than 25 feet, larger diameter tubing is required and field provided.

(Not required for constant volume models.) (ILL. 2)

ILL. 1

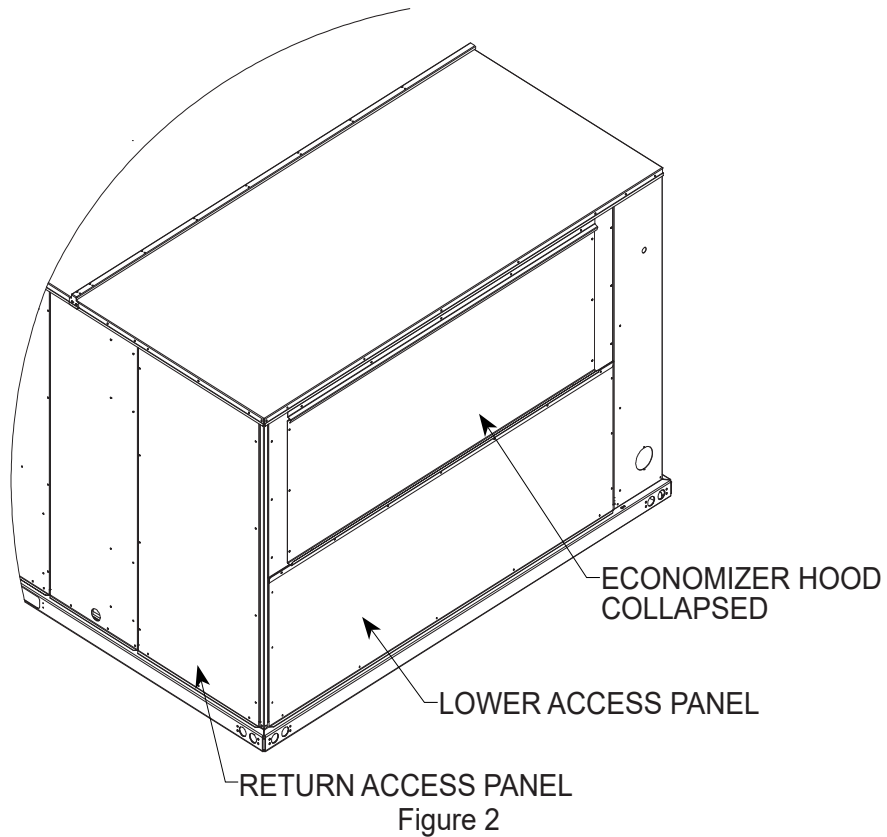
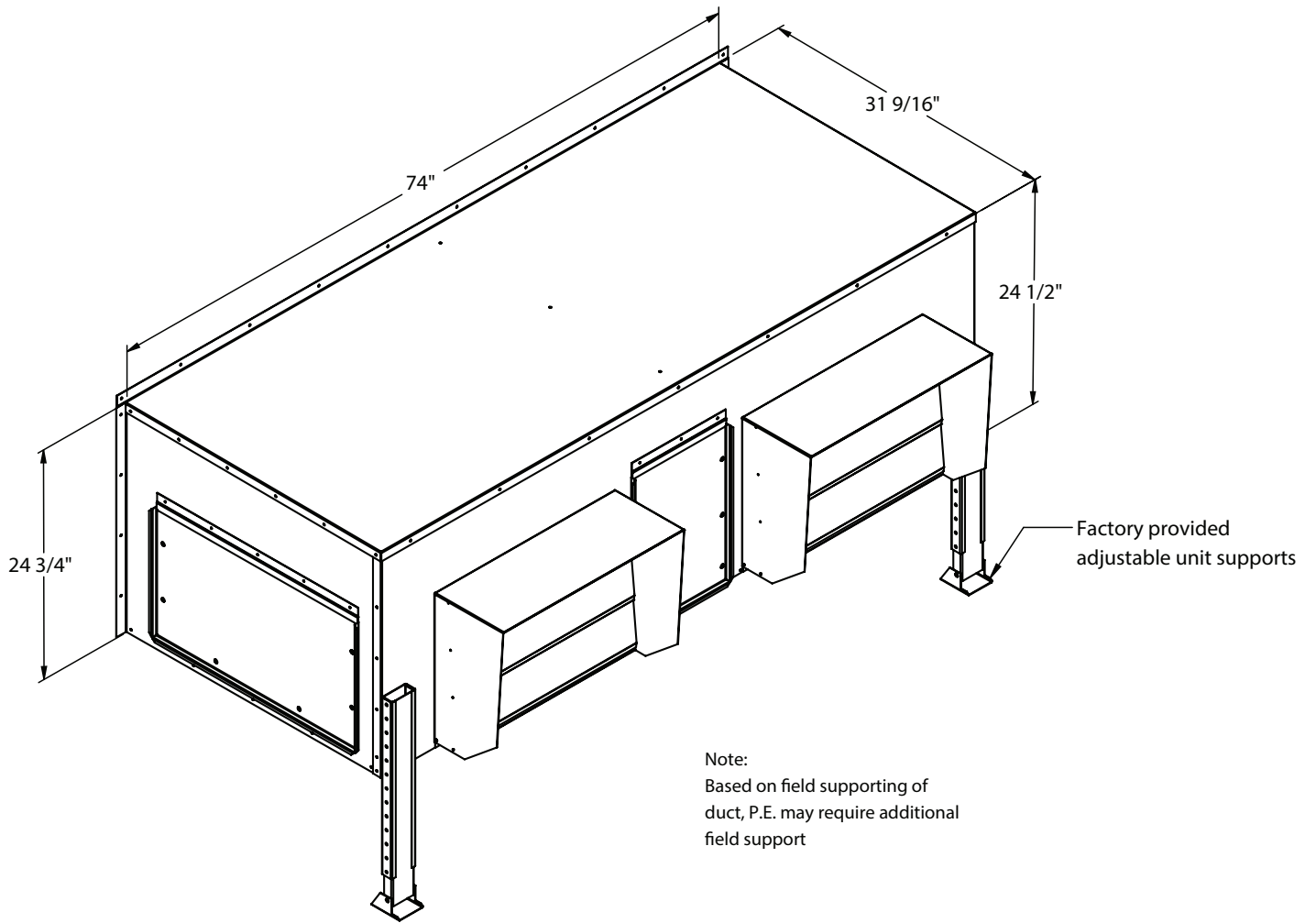

ILL. 2

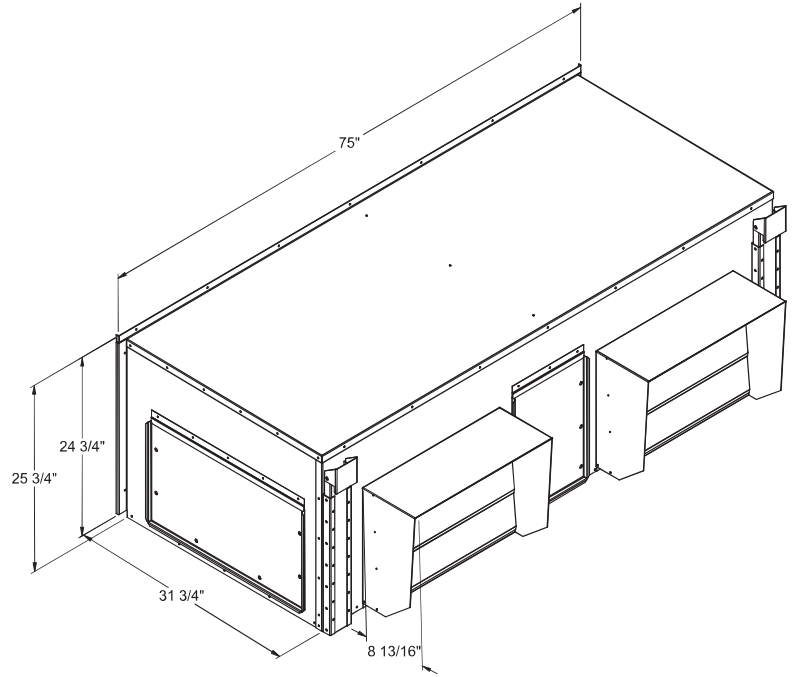

ILL. 4

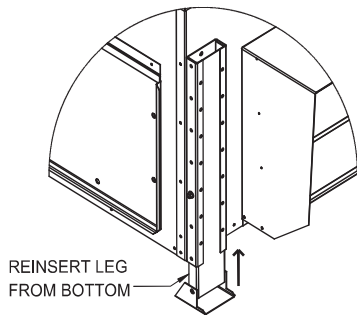
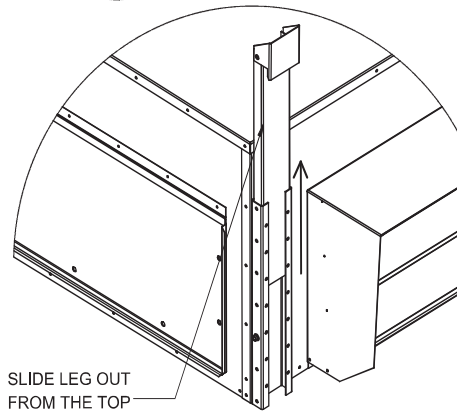
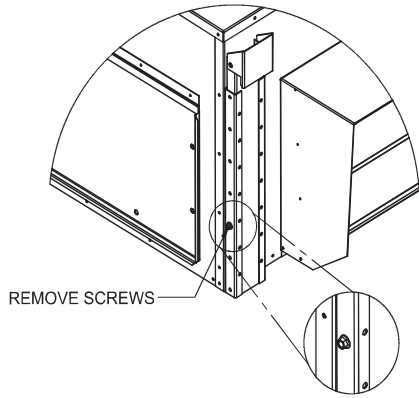

ILL. 3

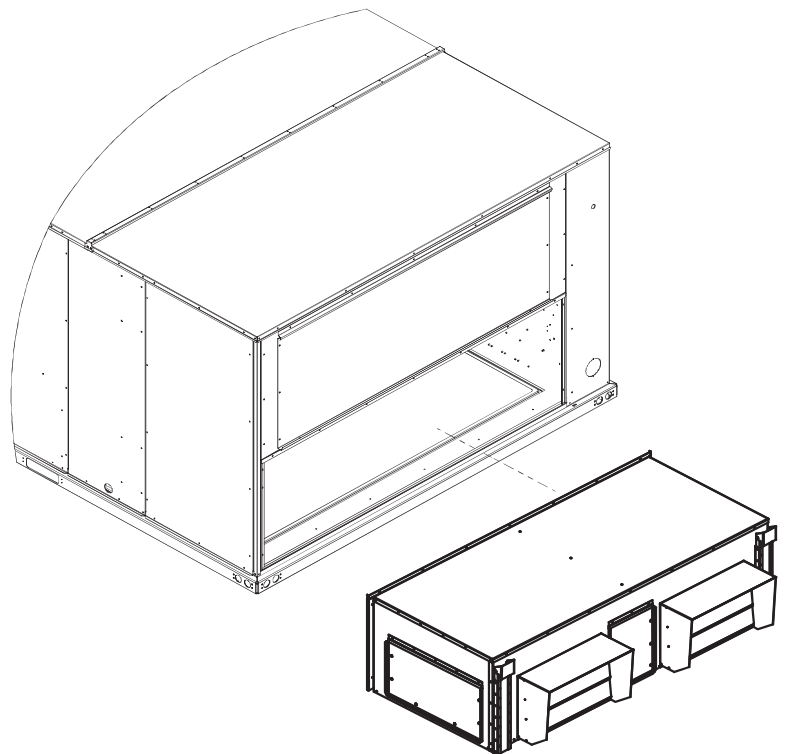

## ILL. 2 - Constant Volume Power Exhaust Wiring Option

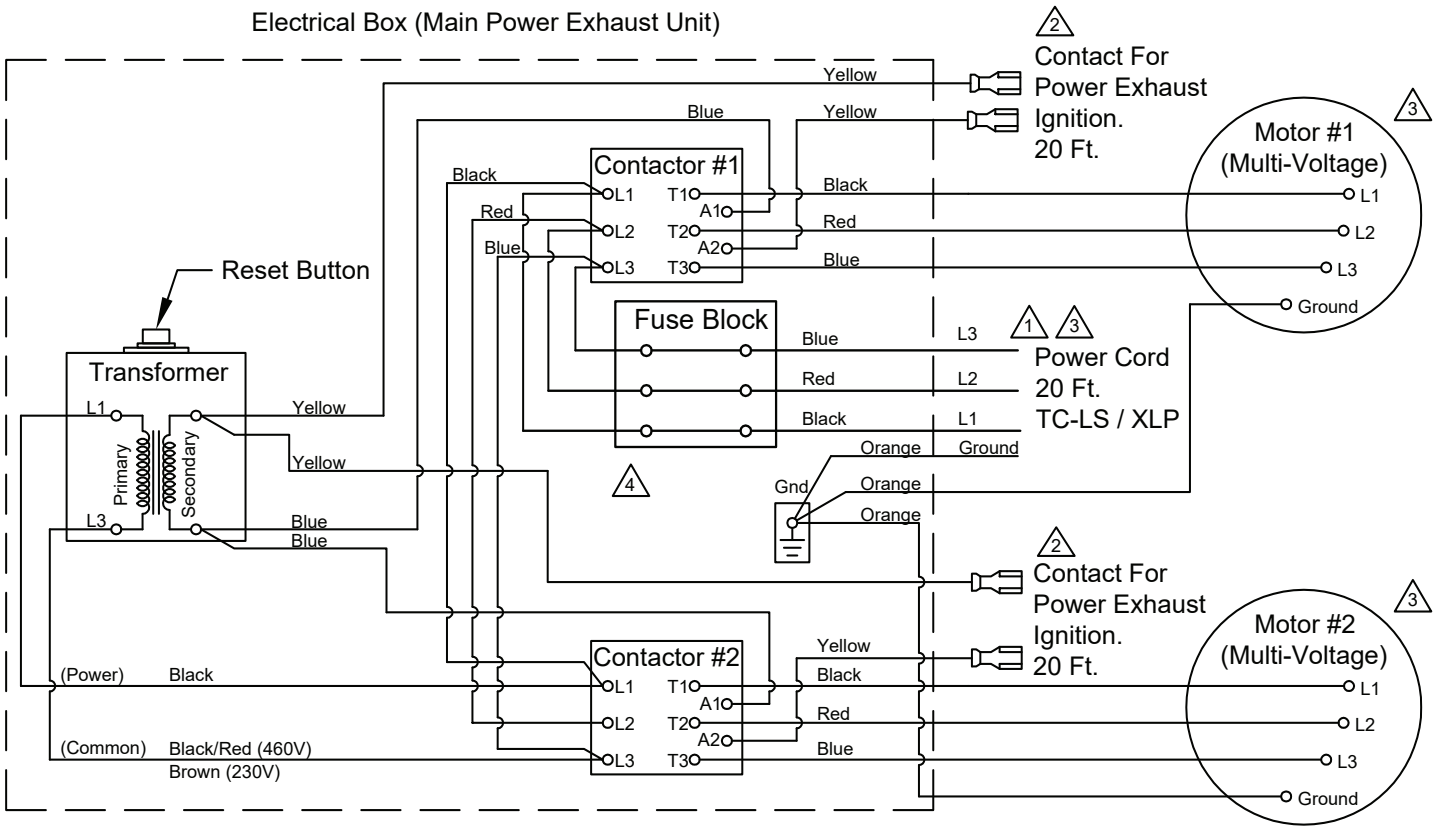

**1** Power Supply. Provide disconnect means and circuit protection as required. See power exhaust name plate for electrical ratings. If local codes allow connecting to the HVAC unit power, make sure the disconnect and incoming wiring are sized to handle the load of both the HVAC unit and the power exhaust.

To determine MCA with power exhaust:  $\text{New MCA} = \text{MCA of Unit Only} + \text{MCA of Power Exhaust}$

**2** Field required.

**3** For voltage, refer to label on exterior of power exhaust cabinet.

**4** For fuse size, refer to label on the exterior of power exhaust cabinet.

## ILL. 3 - Modulating Power Exhaust Option Wiring

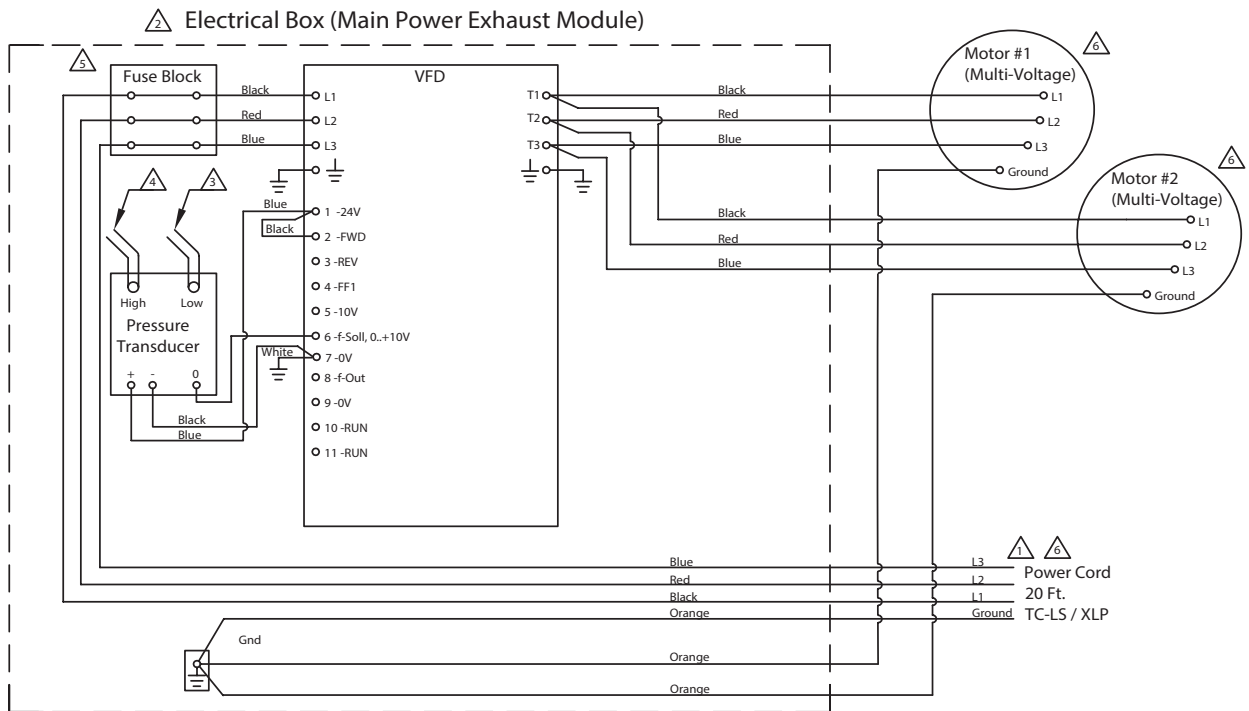

- ⚠ Power Supply. Provide disconnect means and circuit protection as required. See power exhaust name plate for electrical ratings. If local codes allow connecting to the HVAC unit power, make sure the disconnect and incoming wiring are sized to handle the load of both the HVAC unit and the power exhaust.

To determine MCA with power exhaust:  $\text{New MCA} = \text{MCA of Unit Only} + \text{MCA of Power Exhaust}$

- ⚠ Transformer, contactor and fuses are to be in a NEMA type electrical enclosure.
- ⚠ Factory mounted 3/16" low pressure tubing.
- ⚠ 25 feet of 3/16" high pressure tubing and connection port provided for field mounting in conditioned space. Architectural finishing field provided. (Follow local codes.)
- ⚠ For fuse size, refer to label on the exterior of power exhaust cabinet.
- ⚠ For voltage, refer to label on exterior of power exhaust cabinet.
- ⚠ Field required.

The two blower modulating power exhaust are connected to a motor controller (VFD) that varies the speed to maintain an acceptable conditioned space pressure. The power exhaust system includes a low pressure transducer that compares room pressure to atmospheric. This transducer sends a signal to the motor controller (VFD) which varies the motor frequency in order to provide pressure relief.

1. Install 3/16" pressure tubing as per wiring diagram making sure it is not located near any S/A or R/A diffuser or door.
2. The VFD is factory pre programmed to accept the 0 to 10 VDC signal through the pressure transducer.

Table 1 - Pressure vs. VFD Frequency

Transducer Output Signal (VDC)	Conditioned Space Pressure (Inch W.G.)	VFD Setting (Hz)
0	0	0
1	0.01	10
2	0.02	20
3	0.03	30
4	0.04	40
5	0.05	50
6	0.06	60
7	0.07	70
8	0.08	80
9	0.09	90
10	0.10	100

VFD is factory set at 0.04 inches w.g. To change setting, press and hold "OK" to access the programming menu; up/down to display P-45, hit "OK" move arrows up/down to set desired frequency that determines pressure requirement, then press "OK" to save parameter.