

FEATURES:

- CA Title 24 Compliant.
- Factory assembled.
- Galvanized steel construction.
- **AMCA certified CD-60 Airfoil dampers blades.**
- **Meets leakage as required by ASHRAE 90.1**
- Fully insulated.
- Low leak dampers.
- Direct coupled actuator.
- Controls package:
 - Includes dry bulb or enthalpy fully modulating controls. w/relay signal switch.
 - Specific control type: Add the two digits below to the Part Number:
 - DB** For dry bulb control.
 - EN** For enthalpy control.

DAMPER MIXING BOXES FOR YORK AIR HANDLES

Example Shown
P/N: MB-AH*-*-TBE

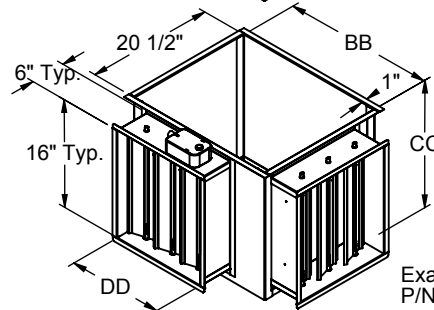
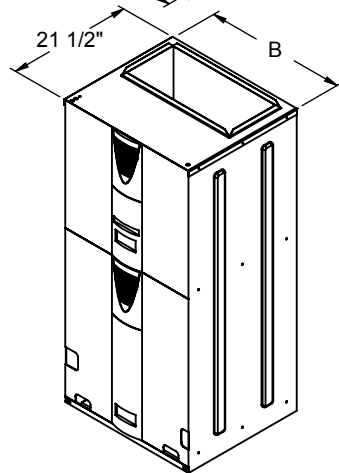
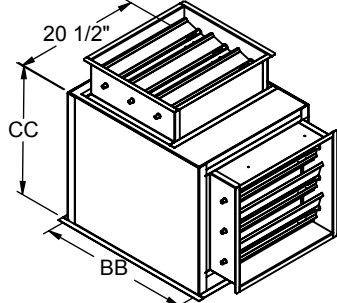

Example Shown
P/N: MB-AH*-*-BFA

UNIT SIZE	PART NUMBER	CONTROL TYPE	B	BB	CC	DD	EST. WT
MP, MA 08-12 AVY24B*21 AH*18-30B*21 AHR18-36B3**21 F4FP024-030* F*R*018-036RC F2F-018-036RC F3F-018-036RC	MB-AHB-AC-***	ACTUATOR ONLY	18"	16"	14" or 20"	10"	65 LBS.
	MB-AHB-DB-***	MODULATING CONTROLS WITH SELECTABLE DRY BULB					
	MB-AHB-EN-***	MODULATING CONTROLS WITH ENTHALPY					
AVY36C*21 AH*34-36C*21 AHR42C3**21 F4FP036-042* F*R*036(RP)-042 F2F*036(RP)-042 F3F*036(RP)-042 MP, MA 16C	MB-AHC-AC-***	ACTUATOR ONLY	21 1/2"	19 1/2"	18" or 20"	14"	70 LBS.
	MB-AHC-DB-***	MODULATING CONTROLS WITH SELECTABLE DRY BULB					
	MB-AHC-EN-***	MODULATING CONTROLS WITH ENTHALPY					
*VY48-60D*21 *HP48-60D*21 *AHX48D*21 F4FP045-060* F5FP045-060* F*R*045-060 F2F*045-060 F3F*045-060	MB-AHD-AC-***	ACTUATOR ONLY	24"	22"	20" or 22"	18"	75 LBS.
	MB-AHD-DB-***	MODULATING CONTROLS WITH SELECTABLE DRY BULB					
	MB-AHD-EN-***	MODULATING CONTROLS WITH ENTHALPY					
AHE42-60D AHX60D*21 AHR48-60D3**21 MA, MP14D MA, MP20D MV12D MV20D	MB-AHE-AC-***	ACTUATOR ONLY	24 1/2"	22 1/2"	20" or 22"	18"	75 LBS.
	MB-AHE-DB-***	MODULATING CONTROLS WITH SELECTABLE DRY BULB					
	MB-AHE-EN-***	MODULATING CONTROLS WITH ENTHALPY					

Mixing Box Position

- T- Top mounted.
- B- Bottom mounted.

Damper Locations

A, B, F, D, or E.
Positions with first position as Return.

(Added to end of part #)

B-Bottom mounted.

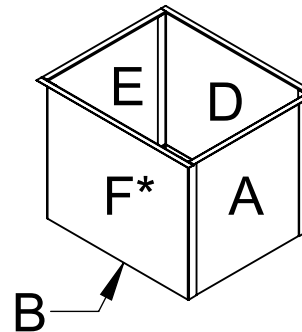

T-Top mounted.

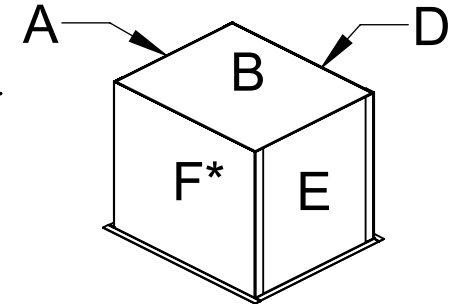

* F Position represents front of Mixing Box which will always match to front of Air Handler.



3847 WABASH DR.
MIRA LOMA, CA 91725

PHONE (951) 685-1101
FAX (619) 872-9799

SUBMITTED TO: _____
COMPANY: _____
JOB NAME: _____
EQUIPMENT: _____
NOTES: _____

FORM NO:
MBAH-01

PART NUMBER:
-

DATE:
9/21/2016

REV:
5

DRAWN BY:
ALL

MIXING BOX DAMPER CONFIGURATION FOR AIR HANDLERS

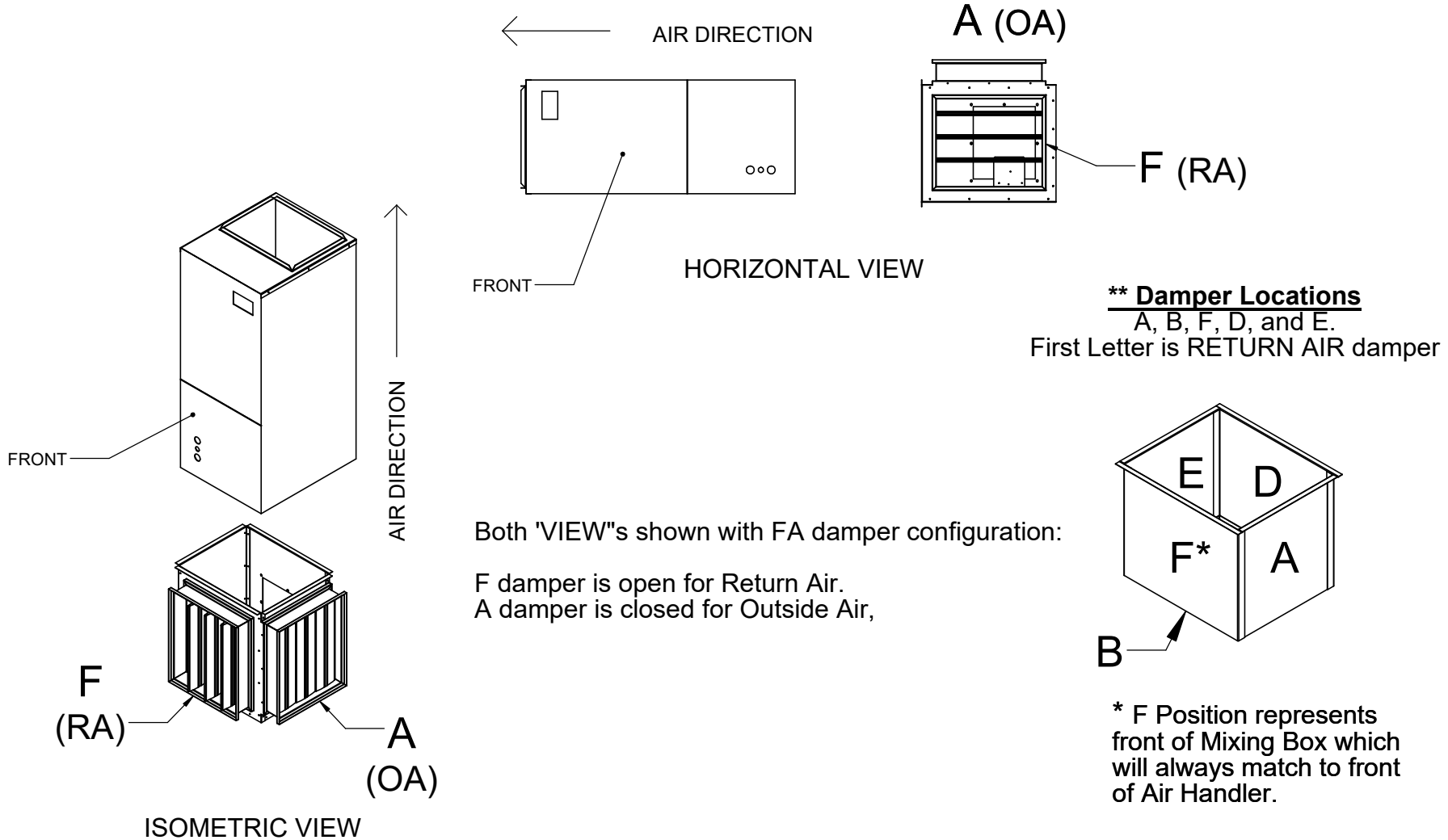

3847 WABASH DRIVE
MIRA LOMA, CA 91725

PHONE (951) 685-1101
FAX (619) 872-9799

SUBMITTED TO: _____
COMPANY: _____
JOB NAME: _____
EQUIPMENT: _____
NOTES: _____

FORM NO:
-
DATE:
5/10/2024

PART NUMBER:
MB DAMPER CONFIG
REV:
-
DRAWN BY:
CNG