

MIXING BOX FOR MULTI POSITION GAS FURNACE

FEATURES:

- Factory assembled.
- Galvanized steel construction.
- Fully insulated.
- Low leak dampers.
- Optional modulating controls with selectable dry bulb or enthalpy are available.
- Direct coupled damper movement.

UNIT SIZE	PART NUMBER	CONTROL TYPE	A	B	EST. WT.
TG9S TG8S***A TM9M,V,Y,E,T***A TM8T,V,X,Y,***A YP9, LC***A	MB-TMA-AC	ACTUATOR ONLY	13 3/8"	12"	61 LBS.
	MB-TMA-DB	MODULATING CONTROLS WITH SELECTABLE DRY BULB			
	MB-TMA-EN	MODULATING CONTROLS WITH ENTHALPY			
TG9S TG8S***B TM9M,V,Y,E,T***B TM8T,V,X,Y,***B YP9, LC***B	MB-TMB-AC	ACTUATOR ONLY	16 3/8"	12"	66 LBS.
	MB-TMB-DB	MODULATING CONTROLS WITH SELECTABLE DRY BULB			
	MB-TMB-EN	MODULATING CONTROLS WITH ENTHALPY			
TG9S TG8S***C TM9M,V,Y,E,T***C TM8T,V,X,Y,***C YP9, LC***C	MB-TMC-AC	ACTUATOR ONLY	19 7/8"	16"	68 LBS.
	MB-TMC-DB	MODULATING CONTROLS WITH SELECTABLE DRY BULB			
	MB-TMC-EN	MODULATING CONTROLS WITH ENTHALPY			
TG9S TG8S***D TM9M,V,Y,E,T***D TM8T,V,X,Y,***D YP9, LC***D	MB-TMD-AC	ACTUATOR ONLY	23 3/8"	16"	80 LBS.
	MB-TMD-DB	MODULATING CONTROLS WITH SELECTABLE DRY BULB			
	MB-TMD-EN	MODULATING CONTROLS WITH ENTHALPY			

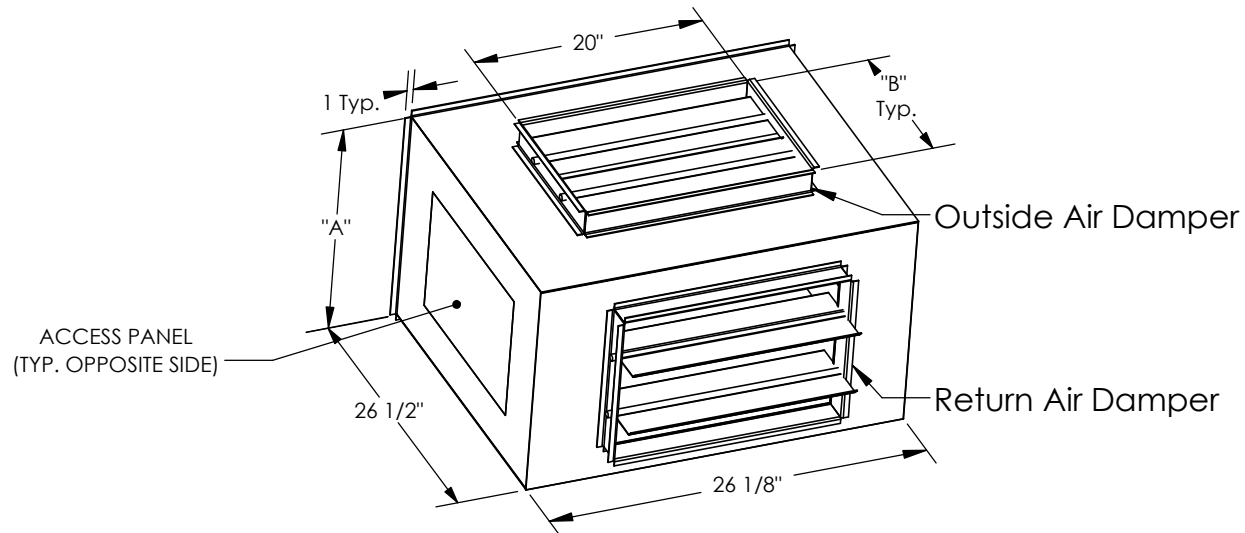

3847 WABASH DRIVE
MIRA LOMA, CA 91752

PHONE (951) 685-1101
FAX (619) 872-9799

SUBMITTED TO: _____
 COMPANY: _____
 JOB NAME: _____
 EQUIPMENT: _____
 NOTES: _____

FORM NO:
MBTM-101

DATE:
5/1/2024

PART NUMBER:
MB-TM SERIES

REV:
8

DRAWN BY:
FMM