

Application

Ruskin Rooftop Systems 530 series concentric diffuser systems are designed to provide a single point air distribution system with the added benefit of having directional air control. The systems may be used with either a "T-Bar" ceiling, a plaster ceiling, or with no ceiling at all.

Features

- Even 4-way air distribution
- All anodized aluminum diffuser frame
- Aluminum return air egg crate
- Double deflection diffuser
- Built-in Anti-Sweat gasket
- Sheet metal transition
- Built-in hanging supports
- Sheet metal diffuser box
- Stainless steel thumb screws
- Fully insulated (both supply and return)

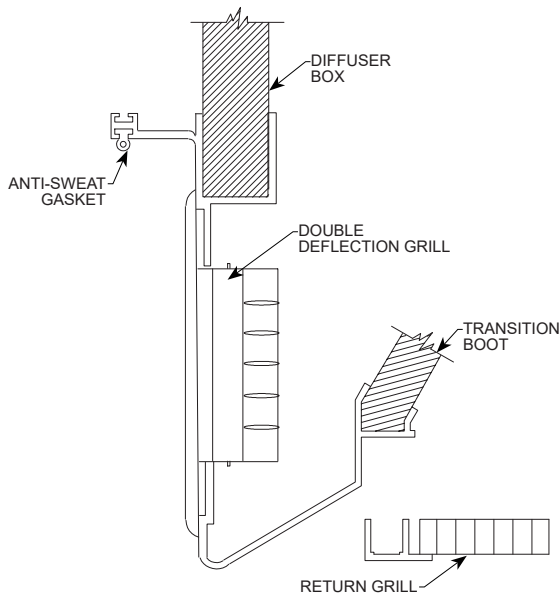
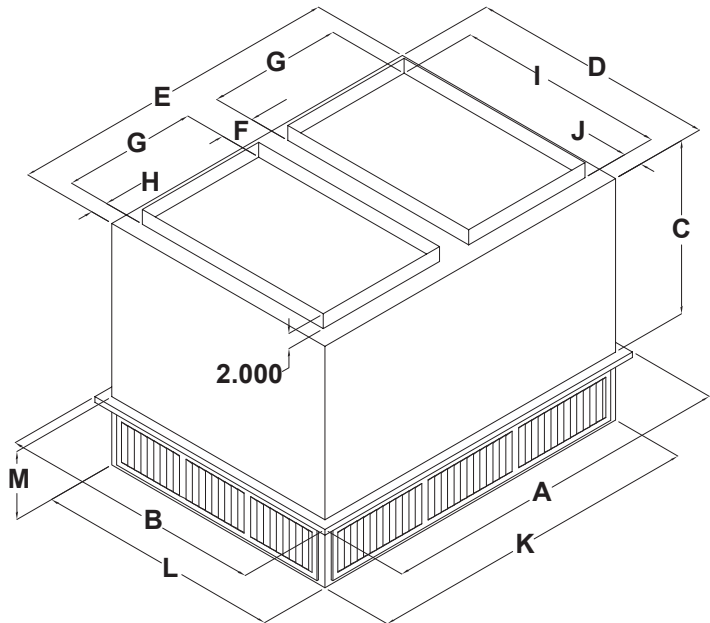

Recommended Specification

Diffusers shall consist of an aluminum supply diffuser with an aluminum egg-crate return. Unit shall be complete with a permanent non-adhesive anti-sweat gasket and hanging supports. Diffusers five ton and smaller shall have a molded fiberglass interior transition. Units fifteen ton and larger shall have supply duct through return transition ensure equal airflow to all four sides of diffuser. Manufacturers published data sheet shall include CFM rating, velocity rating, noise, static, and throw information. Side Discharge mount concentric diffusers shall be in all respects equivalent to Ruskin Rooftop Systems Model 530 Series.

DIMENSIONAL DATA

RRS MODEL#	A	B	C	D	E	F	G	H	I	J	K	L	M	DUCT SIZE
01-530-22B	47.625	35.625	20.625	33.500	45.500	4.500	18	2.500	28	2.750	45.500	33.500	9.125	18 x 28

ENGINEERING DATA

RRS MODEL#	CFM	STATIC PRESSURE	THROW FEET	NECK/JET VEL.	NOISE LEVEL	WEIGHT	GRILL COLOR	FILTER	BOX TYPE
01-530-22B	3600	0.17	25-33	851	30 db	122 lbs	ALUMINUM - GRAY	NOT INCLUDED	SHEET METAL
	3800	0.18	27-35	898					
	4000	0.21	29-37	946					
	4200	0.24	32-40	993					
	4400	0.27	34-42	1040					

JANUARY 7, 2022 FORM# RRS_53022

SUPERSEDES: 07-07-17