

FEATURES:

- Pre-Painted Metal Guard
- Louver Protection

HAIL GUARD/COIL GUARD FOR YORK CORE UNITS

CORE Large Cabinet Shown

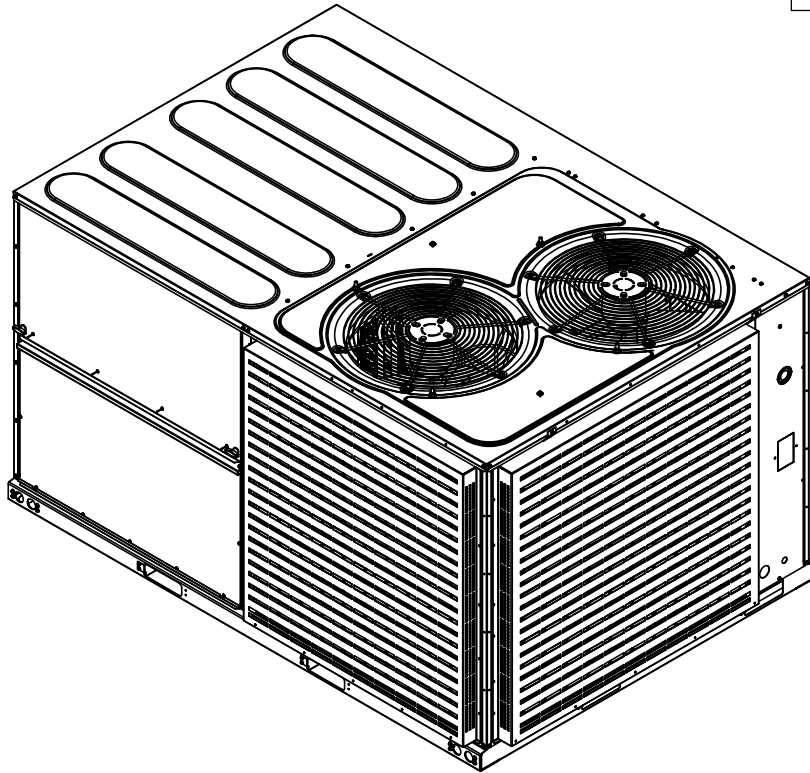

UNIT MODEL	PROVENT P/N	"A"	"B"	"C"	WT.
ZX 04-06; ZQ 04-05 XQ, XY, ZY, ZL 04	CGPRSS	28-3/4"	32-7/8"	23-1/2"	21 Lbs.
ZX 07; ZQ 06; XXA7, ZXA7 XQ, XY, ZY, ZL 05-06	CGPRST	36-3/4"	32-7/8"	23-1/2"	26 Lbs.
ZX 08; XY, ZY 07 XYA7, ZYA7	CGPRLS	36-3/4"	48-5/16"	42-1/4"	41 Lbs.
ZX 09-14; ZY 08-12 XY 08-09; XX 08-10; ZL 08-14	CGPRLT	44-3/4"	48-5/16"	42-1/4"	50 Lbs.

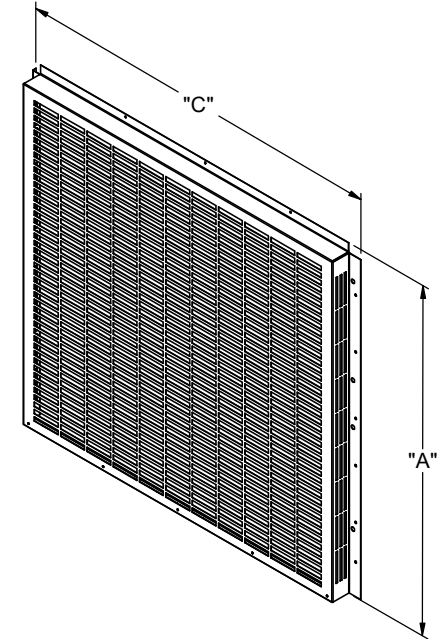
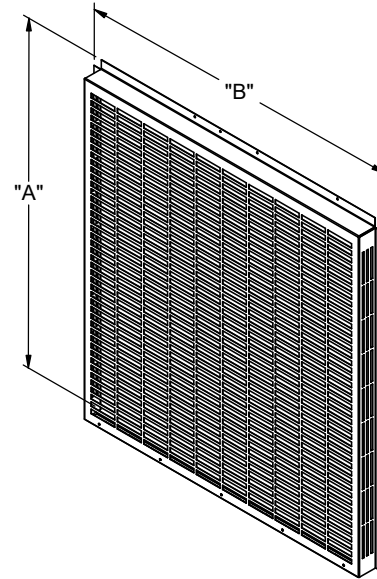

3847 WABASH DRIVE
MIRA LOMA, CA 91752

PHONE (951) 685-1101
FAX (619) 872-9799

SUBMITTED TO: _____
 COMPANY: _____
 JOB NAME: _____
 EQUIPMENT: _____
 NOTES: _____

FORM NO:
CG-201

PART NUMBER:
CGPR Series

DATE:
2/27/2024

REV:
6

DRAWN BY:
CNG