

For wood, concrete and steel attachments see Roof Anchorage Detail, Form Nos. CB-60.

## STRUCTURALLY CALCULATED WELDED ROOF CURBS FOR YORK UNITS

PROVENT P/N	A	EST. WEIGHT
CBWCPRL08	8"	163 Lbs.
CBWCPRL11	11"	177 Lbs.
CBWCPRL614	14	192 Lbs.
CBWCPRL24	24"	240 Lbs.

ZX, 08-14; XX 12  
ZY 07-12; XY 07-09

Meets seismic requirements for the following codes:  
CBC 2016  
IBC 2015

### FEATURES

- Roof curb sides and ends are 16 Ga. galvanized steel.
- Gasketing package provided.
- Heat treated wood nailer provided.
- Insulated deck pans provided.
- Pitched curbs and taller curbs are available.

### Notes

- Attached ductwork to roof curb. Flanges of duct rest on top of curb. Support ductwork below the curb.
- Through the curbs utilities are available. Contact your York distributor or ProVent directly.

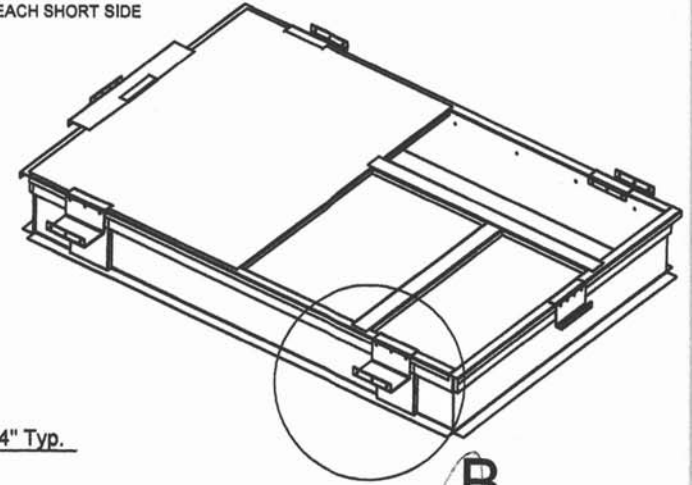
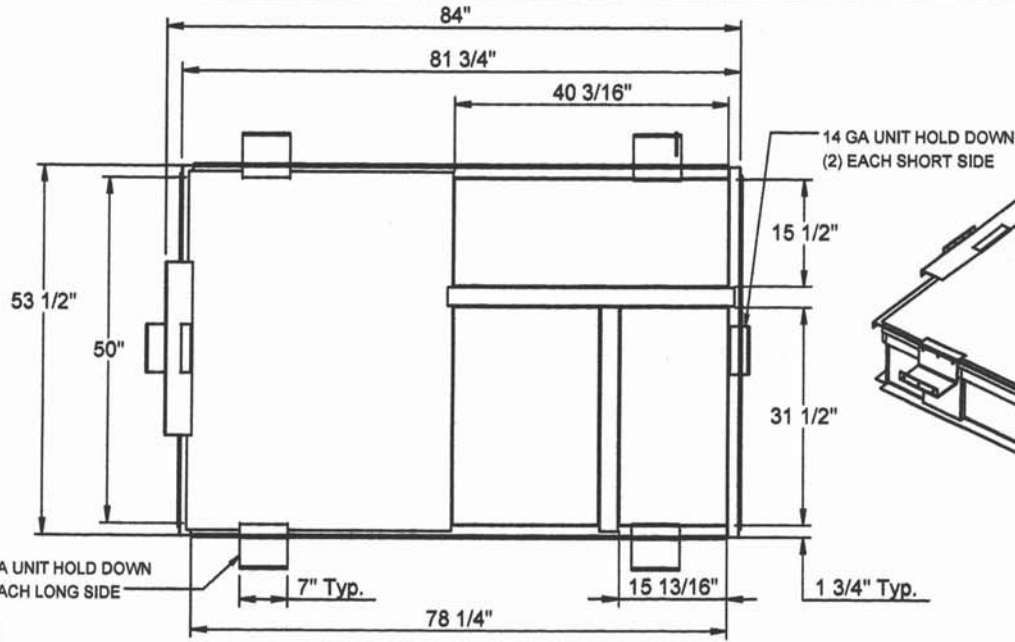

ATTACH TO CURB WITH  
 (5) # 12 x 3/4" @ 6 O.C. TEK SCREWS,  
 EACH SIDE (LONG SIDE)  
 (4) # 10 x 3/4" TEK SCREWS,  
 EACH SIDE (SHORT SIDE)

14 GA UNIT HOLD DOWN  
 (2) EACH LONG SIDE

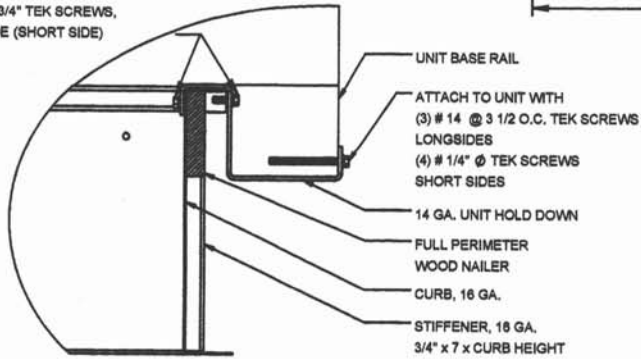

**HOLD DOWN DETAIL**

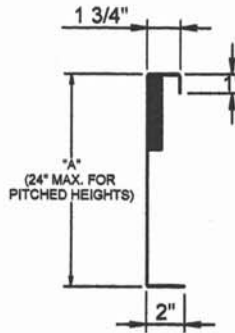

**CURB DETAIL**

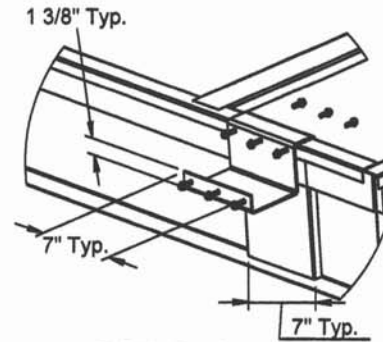

**DETAIL B**

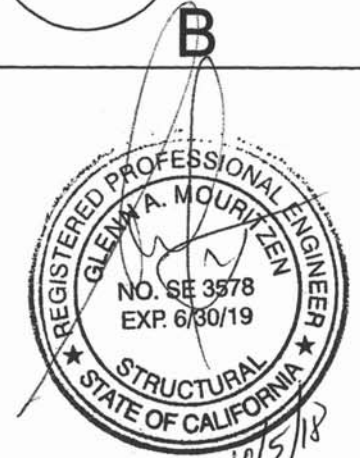

3847 WABASH DRIVE  
 MIRA LOMA, CA 91725

PHONE (951) 685-1101  
 FAX (619) 872-9799

SUBMITTED TO: \_\_\_\_\_  
 COMPANY: \_\_\_\_\_  
 JOB NAME: \_\_\_\_\_  
 EQUIPMENT: \_\_\_\_\_  
 NOTES: \_\_\_\_\_

FORM NO:  
 CBWC-301

DATE:  
 9/27/2018

PART NUMBER:  
 CBWCPRL SERIES

REV:  
 5

DRAWN BY:  
 ALL