

<b>FEATURES</b>	<b>KNOCK-DOWN ROOF CURBS FOR SUN CHOICE UNITS</b>	<b>General Table</b>		
<ul style="list-style-type: none"> <li>• Roof curb perimeter made of galvanized steel.</li> <li>• Gasketing package provided.</li> <li>• Heat treated wood nailer provided.</li> <li>• Corner flanges are pre-threaded for easy bolt on assembly.</li> <li>• Pitched, adjustable pitch/ adjustable height, welded, different height, isolation and calculated curbs are available.</li> </ul>	AV28	<b>PROVENT P/N</b>	<b>A</b>	<b>EST. WEIGHT</b>

- Roof curb perimeter made of galvanized steel.
- Gasketing package provided.
- Heat treated wood nailer provided.
- Corner flanges are pre-threaded for easy bolt on assembly.
- Pitched, adjustable pitch/ adjustable height, welded, different height, isolation and calculated curbs are available.

**NOTES**

- Attach ductwork to roof curb. Flanges of duct rest on top of curb. Support ductwork below the curb.

CBKDSAV2808**	08"	260 Lbs.
CBKDSAV2811**	11"	290 Lbs.
CBKDSAV2814**	14"	320 Lbs.
CBKDSAV2818**	18"	365 Lbs.

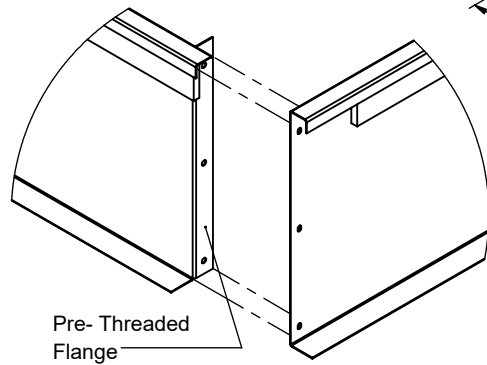
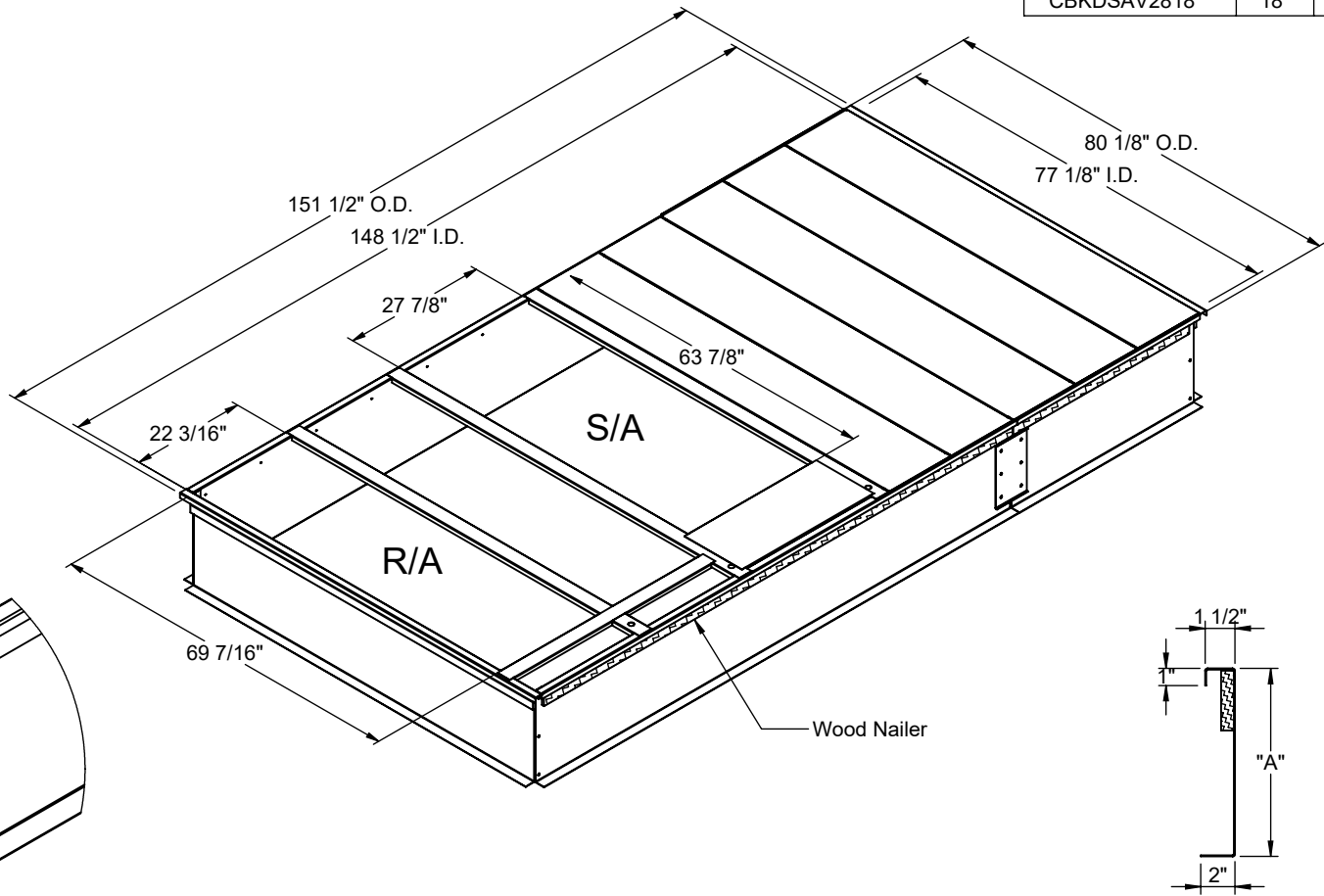

CORNER DETAIL

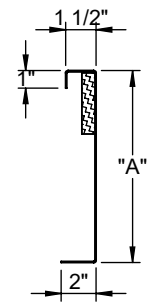

CROSS SECTION DETAIL

	<b>3847 WABASH DRIVE MIRA LOMA, CA 91725</b>	<b>PHONE (951) 685-1101 FAX (619) 872-9799</b>	<b>SUBMITTED TO:</b> _____ <b>COMPANY:</b> _____ <b>JOB NAME:</b> _____ <b>EQUIPMENT:</b> _____ <b>NOTES:</b> _____	<b>FORM NO:</b> -	<b>PART NUMBER:</b> CBKDSAV28 SERIES
	<b>DATE:</b> 6/29/2021	<b>REV:</b> -	<b>DRAWN BY:</b> ALL		