

For wood, concrete and steel attachments see Roof Anchorage Detail, Form No. CB-60.

Will conform to seismic code requirements for knock-down or pre-assembled application. (Contact factory for assembled version.)

STRUCTURALLY CALCULATED HOLD DOWN CLIPS FOR KNOCK-DOWN ROOF CURBS FOR YORK UNITS

**ZT, ZH, ZJ, ZR 037-150
ZF, XP, ZB 078-150**

ProVent P/N	A	WEIGHT	SEISMIC KIT P/N	WEIGHT
CBKDPRD371508	8"	115 Lbs	KDKITPRD371508	8 Lbs
CBKDPRD371511	11"	129 Lbs	KDKITPRD371511	10 Lbs
CBKDPRD371514	14"	144 Lbs	KDKITPRD371514	11 Lbs

Meets seismic requirements for the following codes:
CBC 2019
IBC 2018

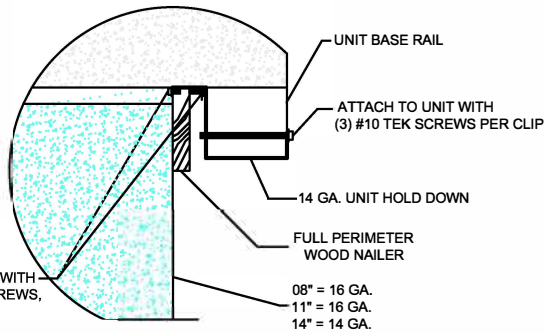
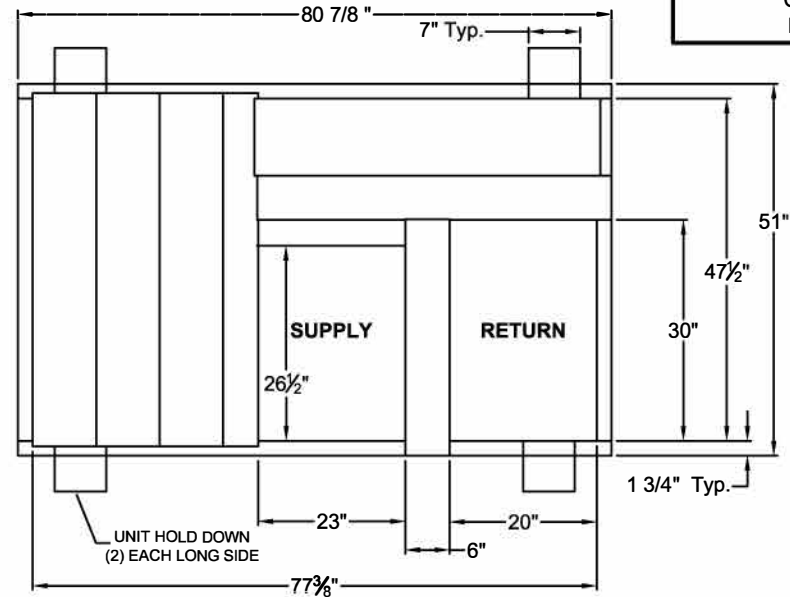
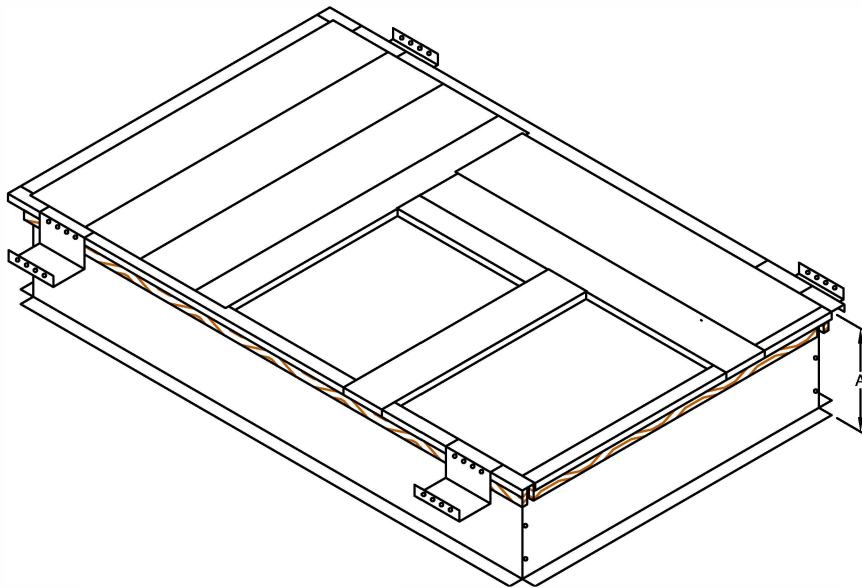

HOLD DOWN DETAIL

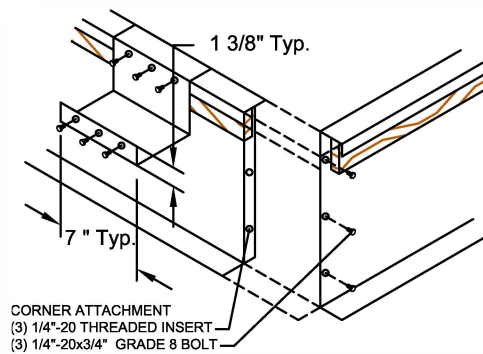

CORNER & HOLD DOWN DETAIL



3847 WABASH DRIVE
MIRA LOMA, CA 91725

PHONE (951) 685-1101
FAX (619) 872-9799

SUBMITTED TO: _____
COMPANY: _____
JOB NAME: _____
EQUIPMENT: _____
NOTES: _____

FORM NO:
CBKD-80

DATE:
9/9/2021

REV:
6

PART NUMBER:
KDKITPRD3715 Series

DRAWN BY:
ALL