

For wood, concrete and steel attachment see Roof Anchorage Detail, Form No. CB-60.

Welded isolation springs housing are standard. For bolted spring housing, neoprene pads and spring cups see Weldment and Bolting Detail, Form No. CB-61

FEATURES

- Roof curb base 12 ga.
- Roof curb upper rail 14 ga.
- Fully welded construction.
- Gasketing package provided.
- Heat treated wood nailer provided.
- Insulated deck pans provided.
- Pitched curbs and taller curbs are available.

NOTES

- Attach ductwork to roof curb. Flanges of duct rest on top of the curb. Support ductwork below the curb.
- Thru the curb utilities are available. Contact your York distributor or Provent directly.

**VIBRATION ISOLATION ROOF CURBS
YORK UNITS**

ZJ, ZR 180-300; XP 180-240
ZF 210-300

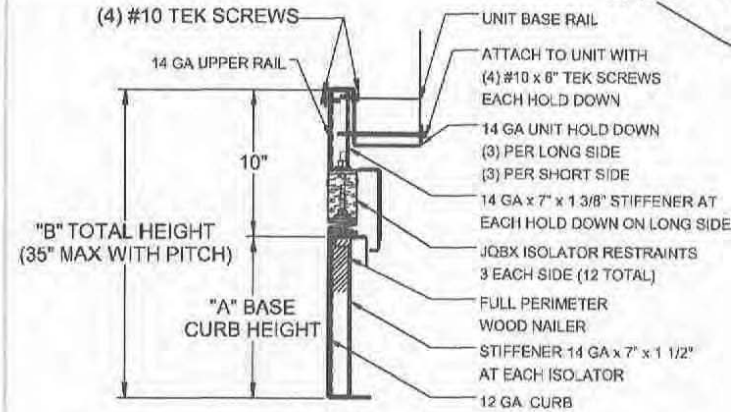
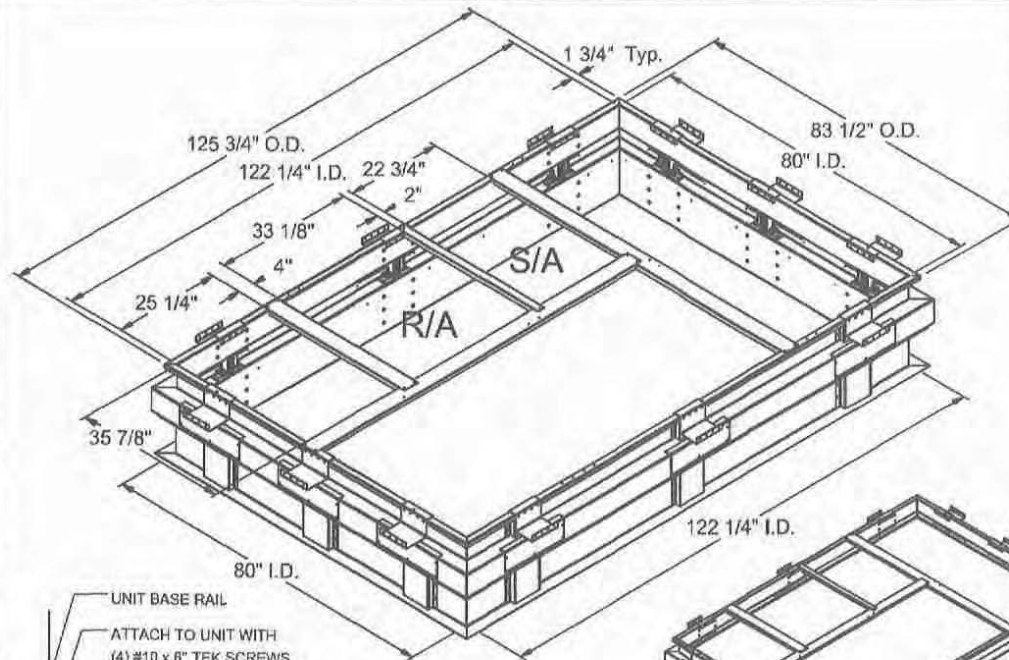

PROFILE DETAIL

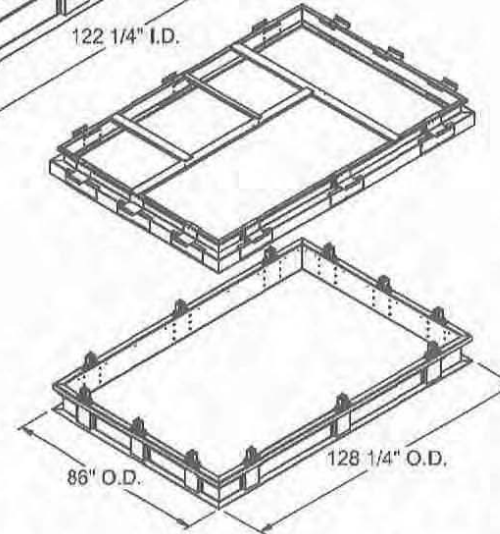

PROVENT P/N	A	B	EST. WEIGHT
CBISCSLM183018**	8"	18"	528 Lbs
CBISCSLM183021**	11"	21"	578 Lbs
CBISCSLM183024**	14"	24"	628 Lbs

**Note: Spring configuration must be added to part number at time of order

Meets seismic requirements for the following codes:
CBC 2016
IBC 2015



3847 WABASH DRIVE
MIRA LOMA, CA 91752

PHONE (951) 685-1101
FAX (619) 872-9799

SUBMITTED TO:
COMPANY:
JOB NAME:
EQUIPMENT:
NOTES:

FORM NO:
CBISC-08
DATE:
9/27/2018

PART NUMBER:
-
REV:
1
DRAWN BY:
ALL