

FEATURES

- Roof curbs sides and ends are Galvanized material.
- Fully welded construction.
- Gasketing package provided.
- Heat treated wood nailer provided.

NOTES

- Attach ductwork to roof curb. Flanges of duct rest on top of the curb, Support ductwork below the curb.
- Thru the curb utilities are available. Contact your distributor or Provent directly.

VIBRATION ISOLATION ROOF CURB FOR:

SUN SELECT 27.5-35 TON UNITS

PROVENT P/N

EST. WEIGHT

CBISSEL283521**

570 Lbs.

**Note: Spring configuration must be added to part number at time of order

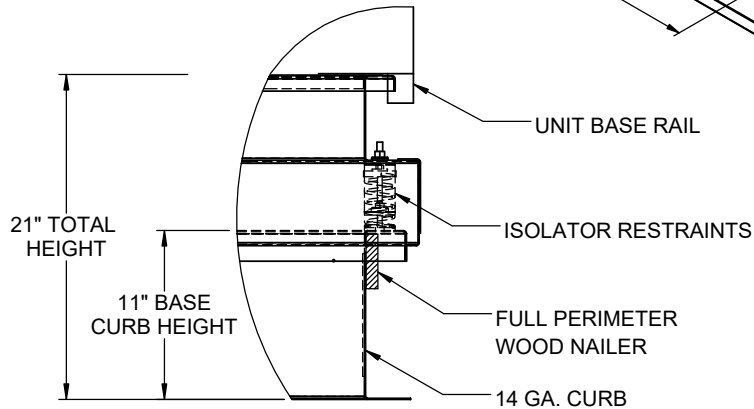
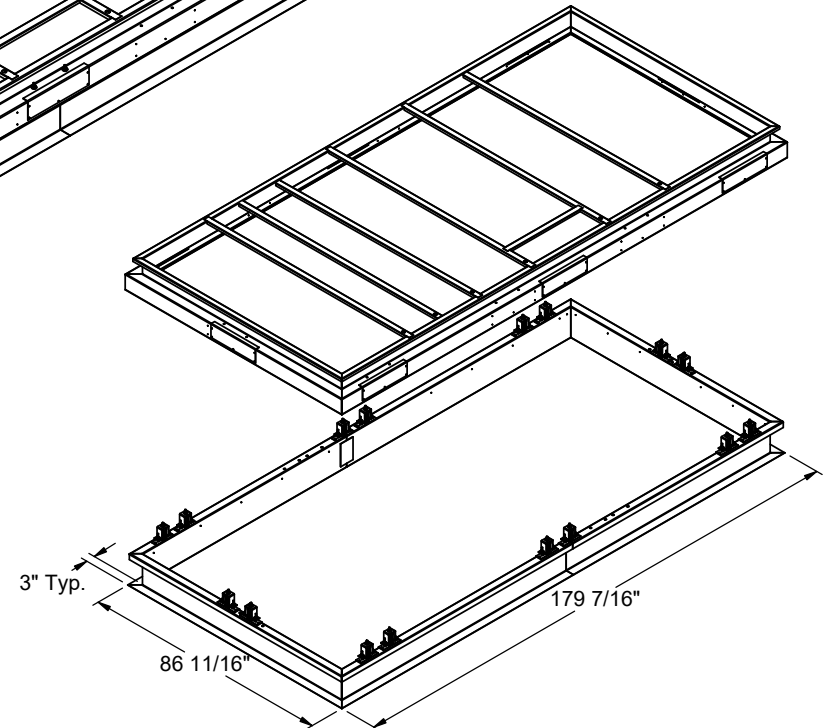
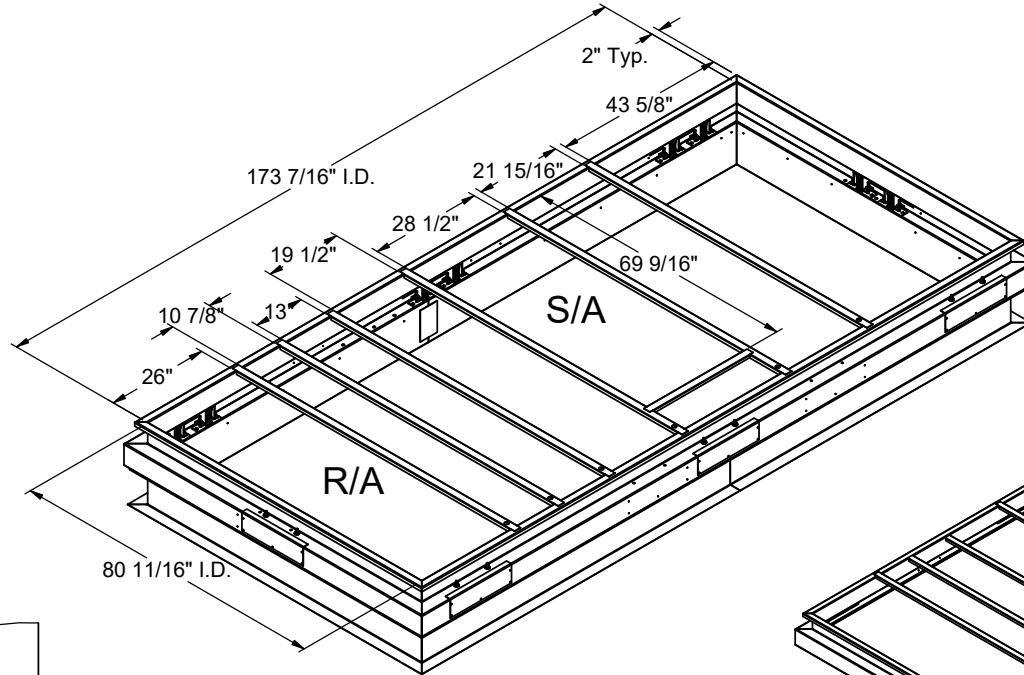

PROFILE DETAIL



3847 WABASH DRIVE
MIRA LOMA, CA 91752

PHONE (951) 685-1101
FAX (619) 872-9799

SUBMITTED TO: _____
 COMPANY: _____
 JOB NAME: _____
 EQUIPMENT: _____
 NOTES: _____

FORM NO:

-

PART NUMBER:

CBISSEL283521

DATE:

4/28/2020

REV:

1

DRAWN BY:

FMM