

FEATURES

- Roof curbs sides and ends are 16 ga.
- Fully welded construction.
- Gasketing package provided.
- Heat treated wood nailer provided.
- insulated deck pans provided.
- Pitched curbs and taller curbs are available.

NOTES

- Attach ductwork to roof curb. Flanges of duct rest on top of the curb, Support ductwork below the curb.
- Thru the curb utilities are available. Contact you York distributor or Provent directly.

**VIBRATION ISOLATION ROOF CURBS
SUNCHOICE UNITS**

PROVENT P/N

EST. WEIGHT

CBISSAV202521**

600 Lbs.

**Note: Spring configuration must be added to part number at time of order

20-25

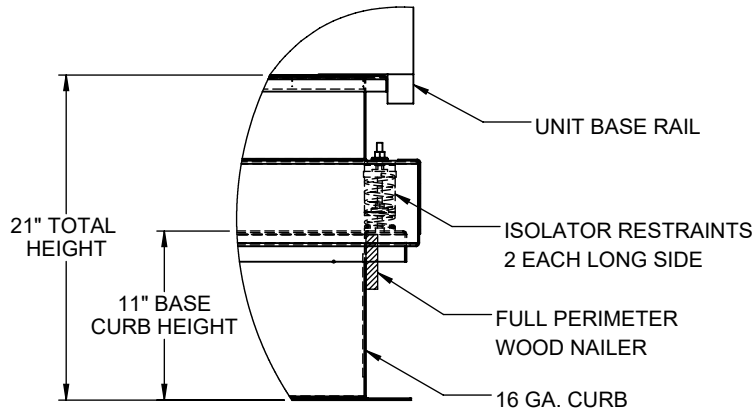
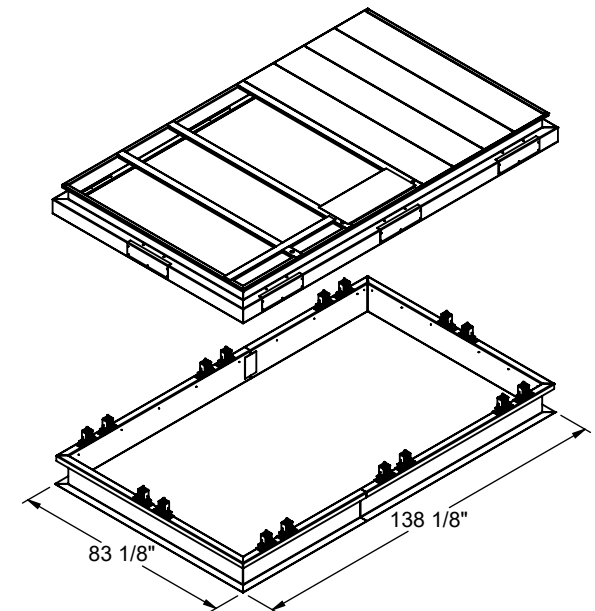
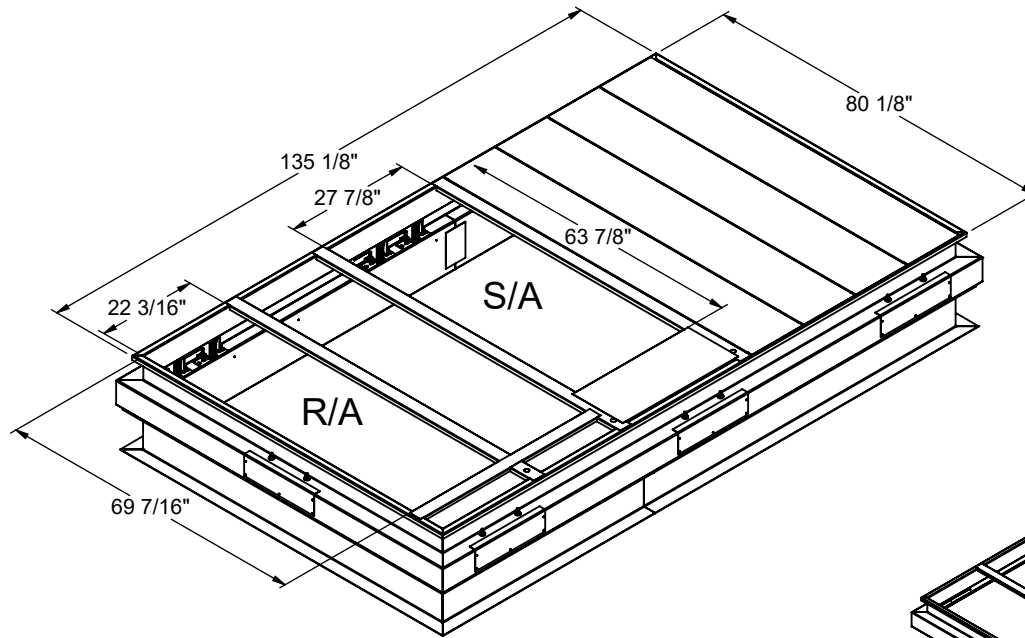

PROFILE DETAIL



3847 WABASH DRIVE
MIRA LOMA, CA 91752

PHONE (951) 685-1101
FAX (619) 872-9799

SUBMITTED TO: _____
COMPANY: _____
JOB NAME: _____
EQUIPMENT: _____
NOTES: _____

FORM NO:

-

DATE:

7/12/2021

PART NUMBER:

CBISSAV2025 SERIES

REV:

-

DRAWN BY:

ALL