

FEATURES

- Roof curb sides and ends are 16 ga. galvanized steel.
- Fully welded construction.
- Gasketing package provided.
- Heat treated wood nailer provided.
- Pitched, different height, taller and calculated curbs are available.
- Restraints and springs have OSHPD Pre-Approval, OPA #0070.

NOTES

- Attach ductwork to roof curb. Flanges of duct rest on top of curb. Support ductwork below the curb.

VIBRATION ISOLATION CURBS FOR YORK UNITS

ZR 036-060, XP 036-060, ZF 036-072

ProVent P/N	A	B	WEIGHT
CBISSUN367218	8"	18"	240 Lbs
CBISSUN367221	11"	21"	253 Lbs
CBISSUN367224	14"	24"	265 Lbs

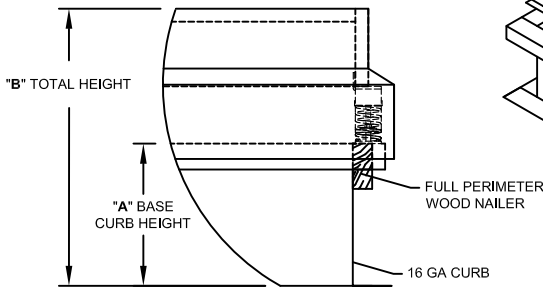
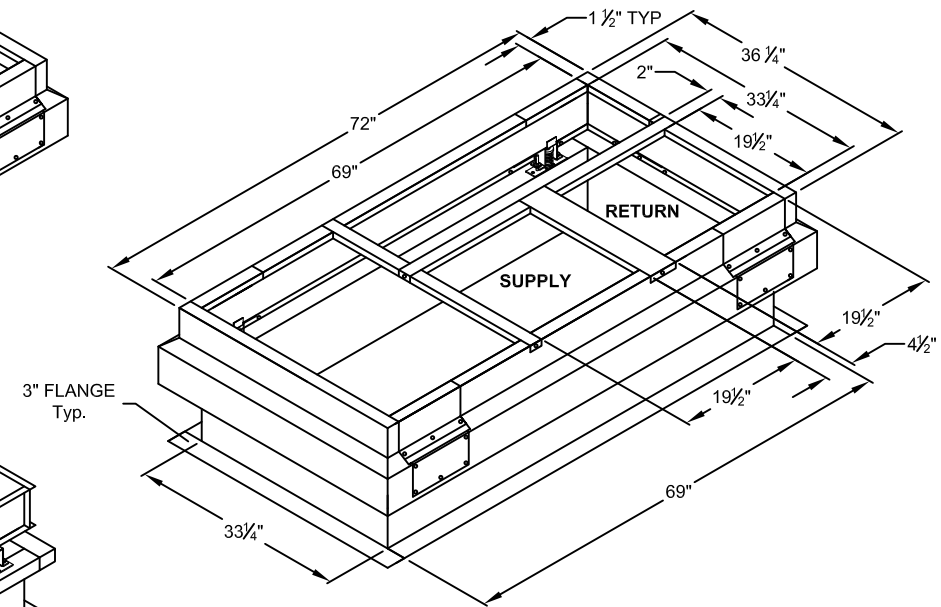
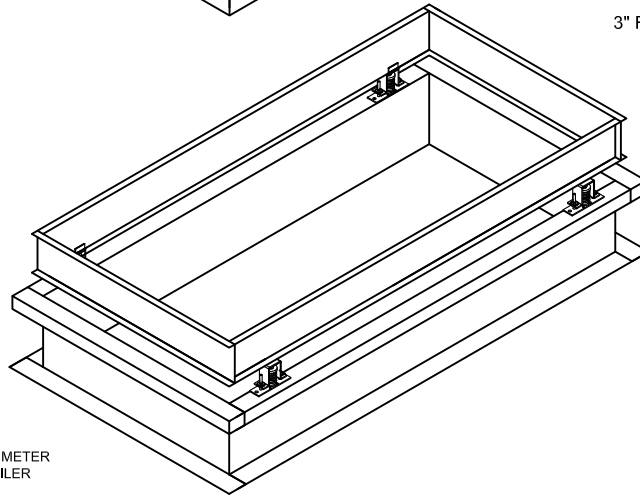
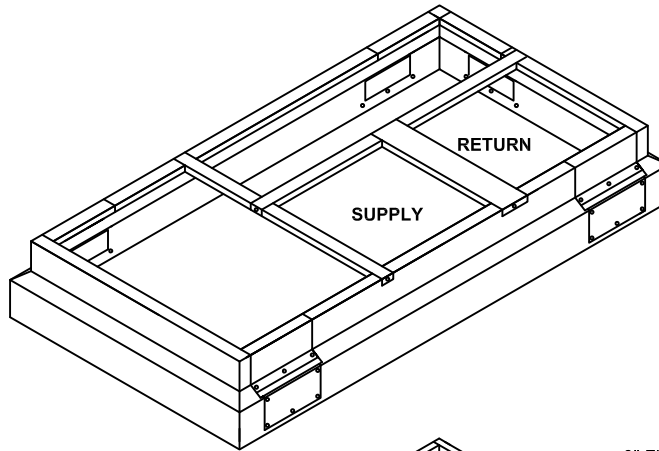

PROFILE DETAIL



3847 WABASH DRIVE
MIRA LOMA, CA 91752

PHONE (951) 685-1101
FAX (619) 498-9247

SUBMITTED TO: _____
 COMPANY: _____
 JOB NAME: _____
 EQUIPMENT: _____
 NOTES: _____

FORM NO: CBIS-102
 DATE: 10/6/14
 REV: 3

PART NUMBER: CBISSUN3672 SERIES
 DRAWN BY: CNG