

FEATURES:

- Gasketing package provided.
- Insulation: 1"-1.5 lb. Density.
- Estimated Weight: 275 Lbs.
- All Galvanized Welded Construction.

CURB ADAPTER

EXISTING TRANE:
 TCD/YCD 061C-074C; 075A,B,C 086C, 090A,B,C,D, 091C,D, 102C
 TCD120C, YCD 120C LOW/MED HEAT; WCD 075A,C, 090A,C

FOR YORK UNITS:
 ZX, ZY 08-12; ZX 14; ZY 07

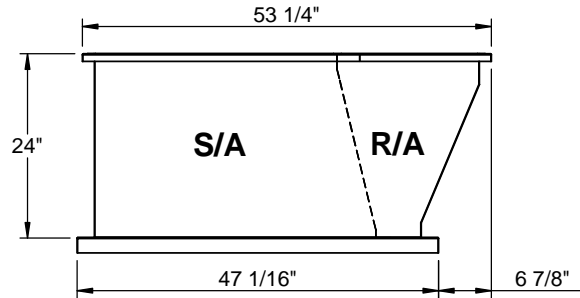

FRONT VIEW

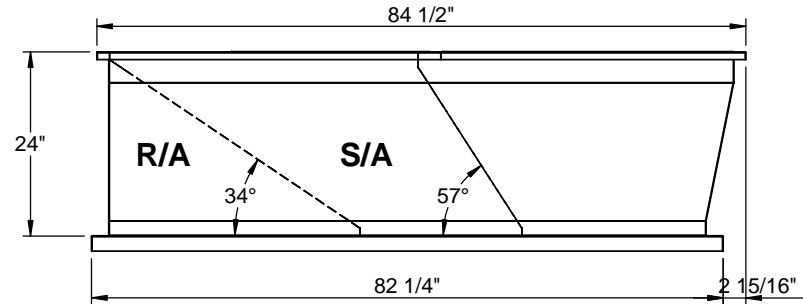

RIGHT VIEW

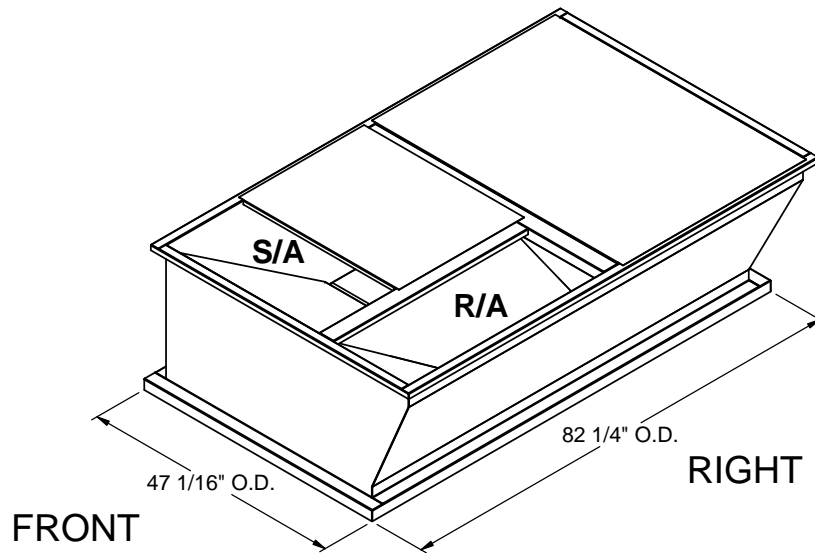

ISOMETRIC VIEW

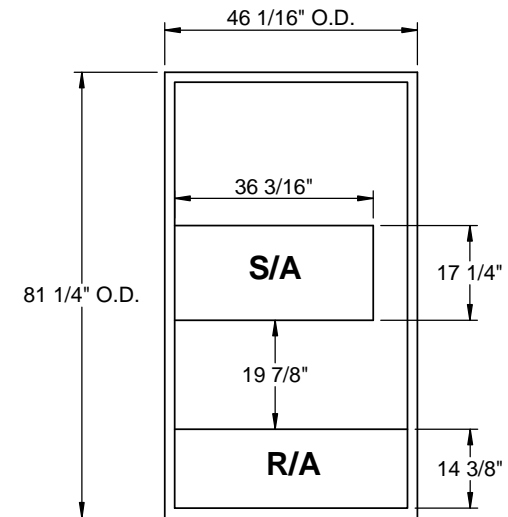

EXISTING CURB



3847 WABASH DRIVE
 MIRA LOMA, CA 91752

PHONE (951) 685-1101
 FAX (619) 872-9799

SUBMITTED TO: _____
 COMPANY: _____
 JOB NAME: _____
 EQUIPMENT: _____
 NOTES: _____

FORM NO:
 -

PART NUMBER:
 CA-PRL-TRN01

DATE:
 9/18/2015

REV:
 -

DRAWN BY:
 CNG