

FEATURES:

- Gasketing package provided.
- Insulation: 1"-1.5 lb. Density.
- Estimated Weight: 198 Lbs.
- All Galvanized Welded Construction.

CURB ADAPTER

EXISTING TRANE:
 SACA, SFCA 100: SFCA, SFCB, SACA 125:
 SACC, SFCB C12-14: BYC 150G

FOR YORK UNITS:
 ZH/ZR/XP/DH/DM/DF/DR/BP 078-150: DJ 150

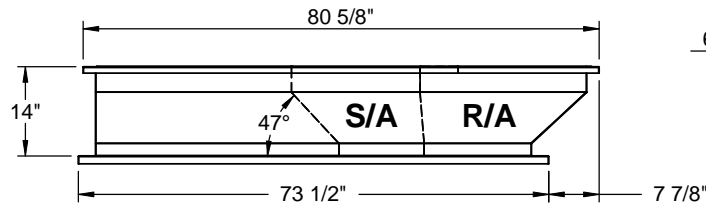

FRONT VIEW

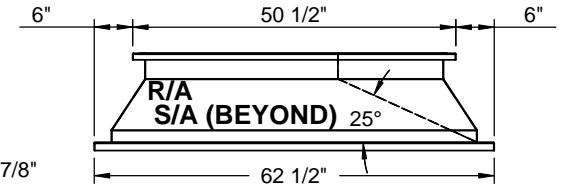

RIGHT VIEW

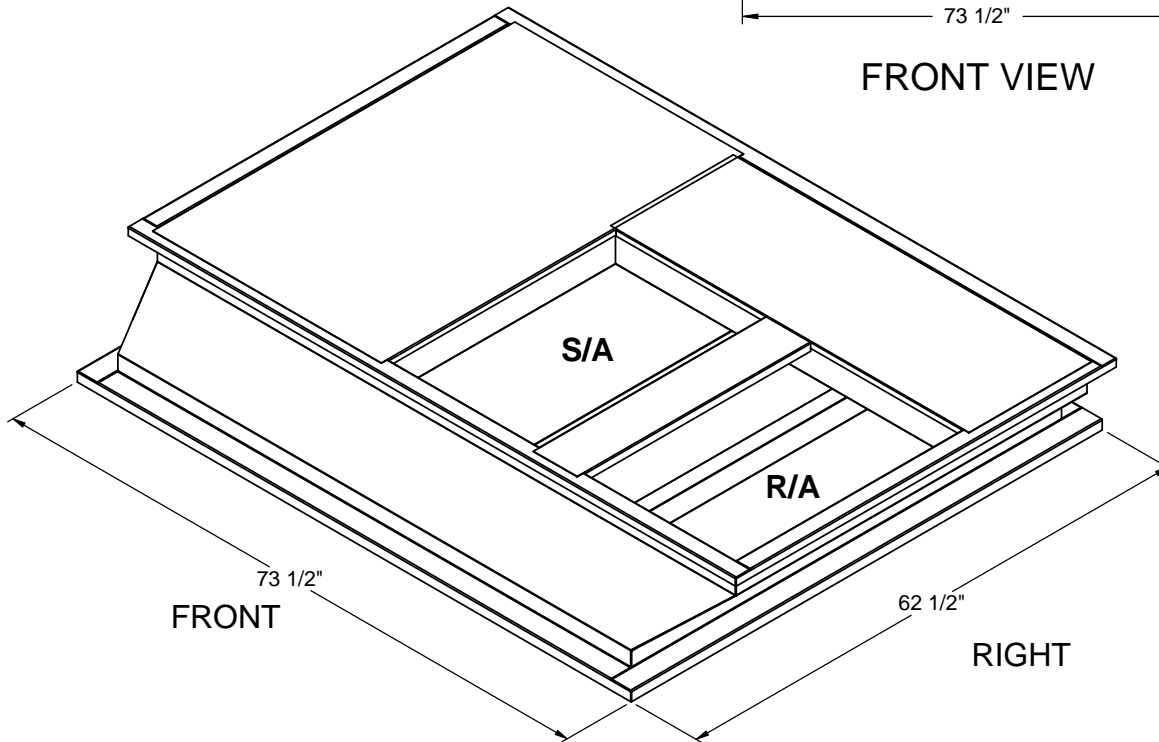

ISOMETRIC VIEW

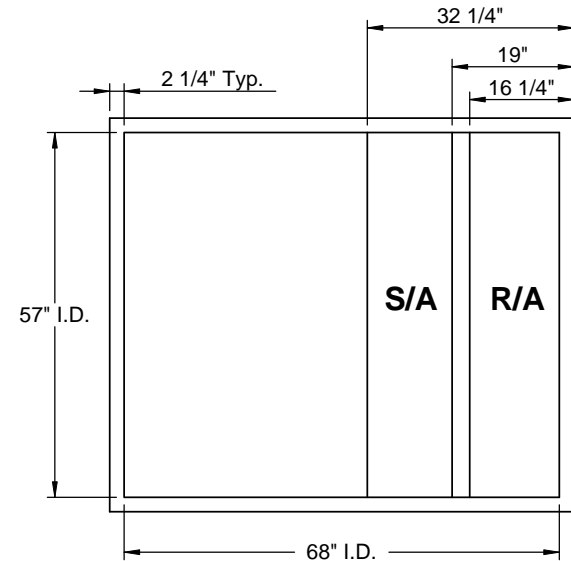

EXISTING CURB



3847 WABASH DRIVE
 MIRA LOMA, CA 91752

PHONE (951) 685-1101
 FAX (619) 872-9799

SUBMITTED TO: _____
 COMPANY: _____
 JOB NAME: _____
 EQUIPMENT: _____
 NOTES: _____

PART NUMBER:
 CA-PRD7815-TRN-08

DATE:
 7/18/2011

REV:
 1

DRAWN BY:
 CNG