

**FEATURES:**

- Gasketing package provided.
- Insulation: 1"-1.5 lb. Density.
- Estimated Weight: 111 Lbs.
- All Galvanized Welded Construction.

**CURB ADAPTER**

EXISTING CARRIER:  
48KL, GL, KLA 024-036; 48KH, GH, KHA, 024-030;

EXISTING BRYANT:  
585C, E, G, H, J 018-036060

FOR YORK UNITS:  
P\*\*4A UNITS

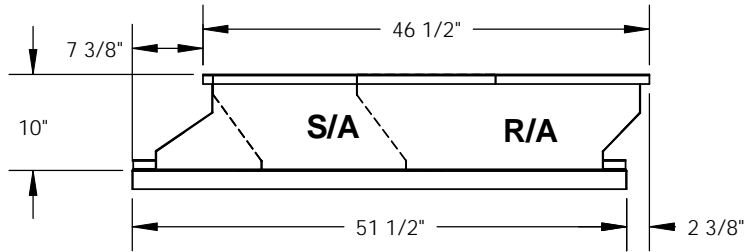

**FRONT VIEW**

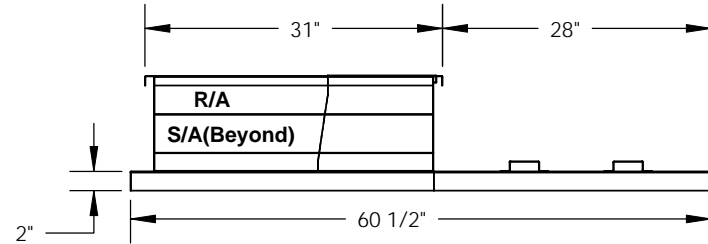

**RIGHT VIEW**

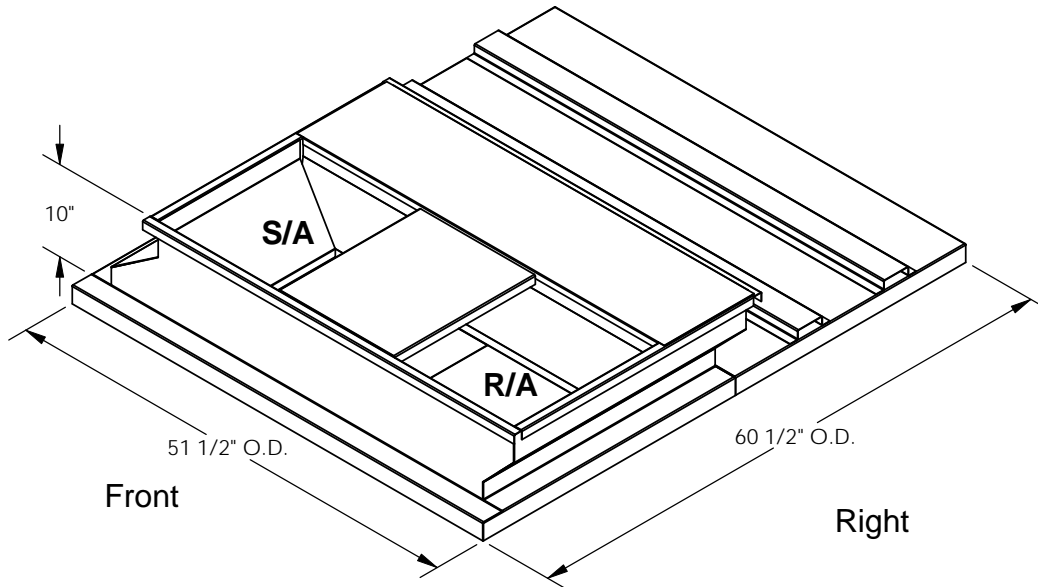

**ISOMETRIC VIEW**

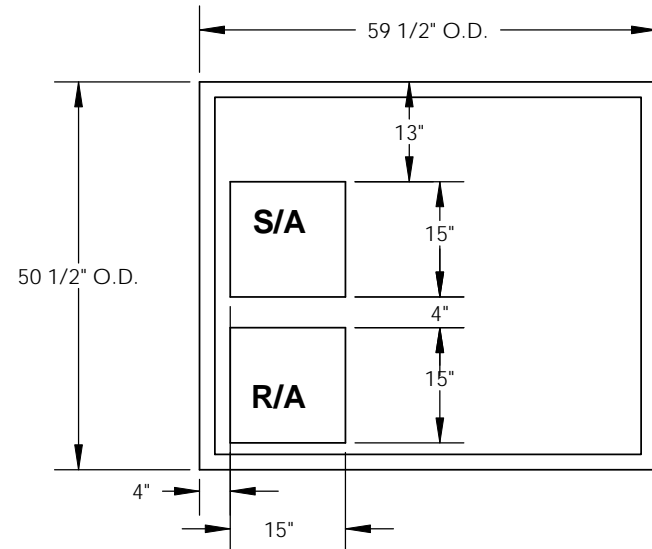

**EXISTING CURB**



3847 WABASH DRIVE  
MIRA LOMA, CA 91752

PHONE (951) 685-1101  
FAX (619) 872-9799

SUBMITTED TO: \_\_\_\_\_  
COMPANY: \_\_\_\_\_  
JOB NAME: \_\_\_\_\_  
EQUIPMENT: \_\_\_\_\_  
NOTES: \_\_\_\_\_

FORM NO: \_\_\_\_\_  
DATE: 5/19/2016

PART NUMBER:  
CA-LXS-CAR15  
REV: -  
DRAWN BY:  
CNG