

FEATURES:

- Material: Galvanized steel.
- Gasketing package provided.
- Heat treated wood nailer provided.
- Estimated Weight: 39 Lbs.

CURB ADAPTER

EXISTING TRANE:
2/4 YCC 042-060

FOR YORK UNITS:
PCG4 048-060

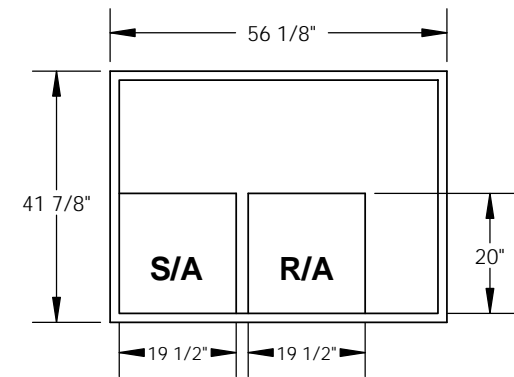
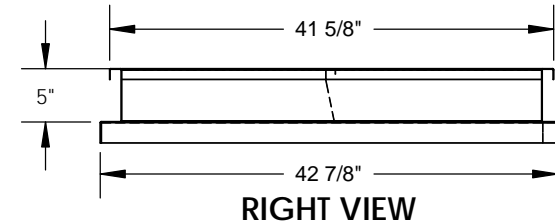
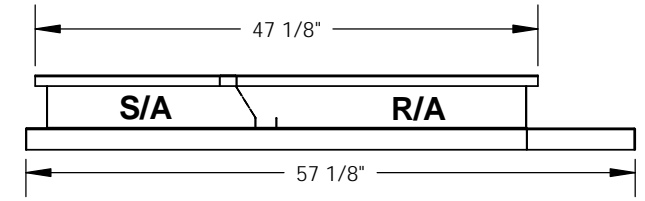
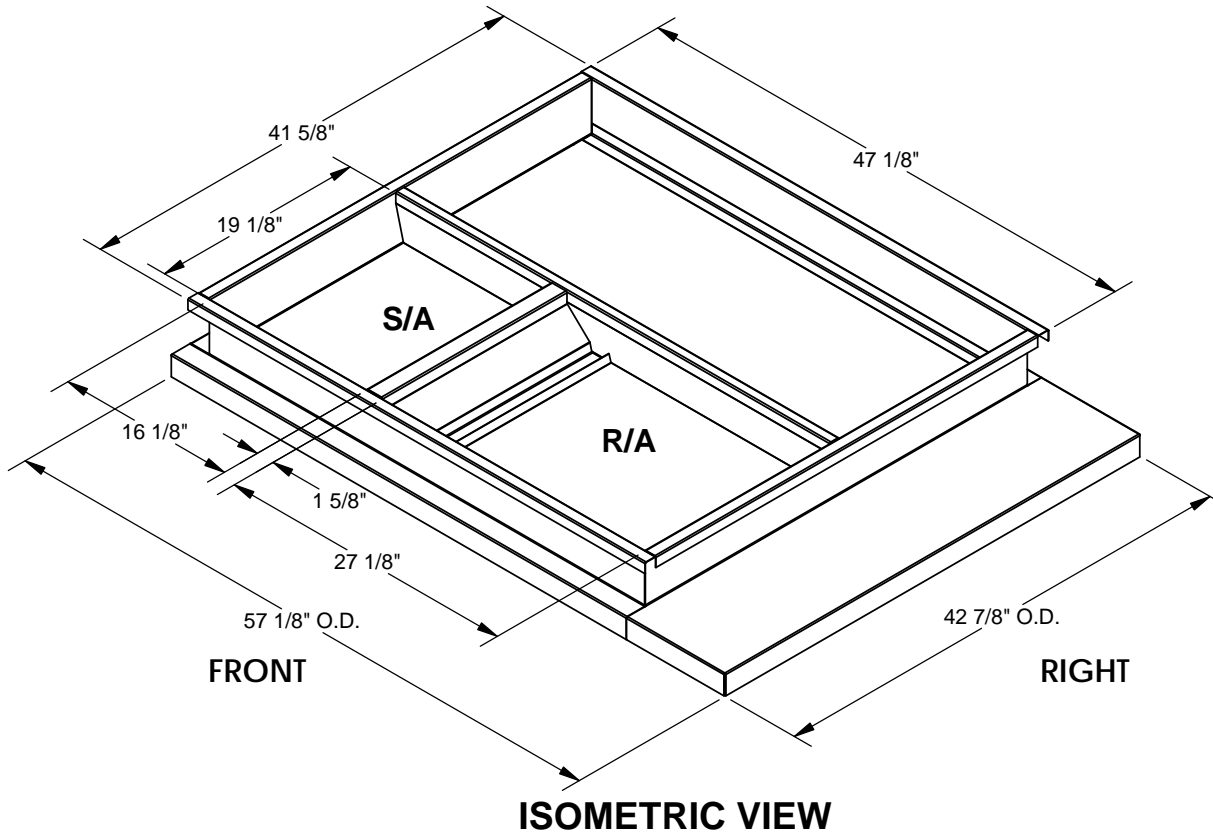

NOTE: Curb dimensions and Return/ Supply openings must be verified prior to ordering due to the variance in Trane curbs from the Factory. ProVent cannot be responsible for fitment issues.



3847 WABASH DR.
MIRA LOMA, CA 91725

PHONE (951) 685-1101
FAX (619) 872-9799

SUBMITTED TO: _____
 COMPANY: _____
 JOB NAME: _____
 EQUIPMENT: _____
 NOTES: _____

FORM NO:
-

PART NUMBER:
CA-LXL-TRN01

DATE:
9/14/2015

REV:
2

DRAWN BY:
JG