

FEATURES

- Simple bolt on assembly. (All bolt connections are pre-threaded.)
- GS90 Galvanized Steel
- Foot mount bolt locations are pre-punched for simple bolt on anchoring.

STACKING RACK FOR SAMSUNG "AM" SERIES CONDENSING UNITS

PROVENT P/N	UNIT	A	B	Wt.
STACKSAMAM-01	AM 036-053 TX, FX, NXMDCH	60"	53"	188 Lbs.
STACKSAMAM-02	AM 060 MX, NXMDCH	67"	61"	198 Lbs.

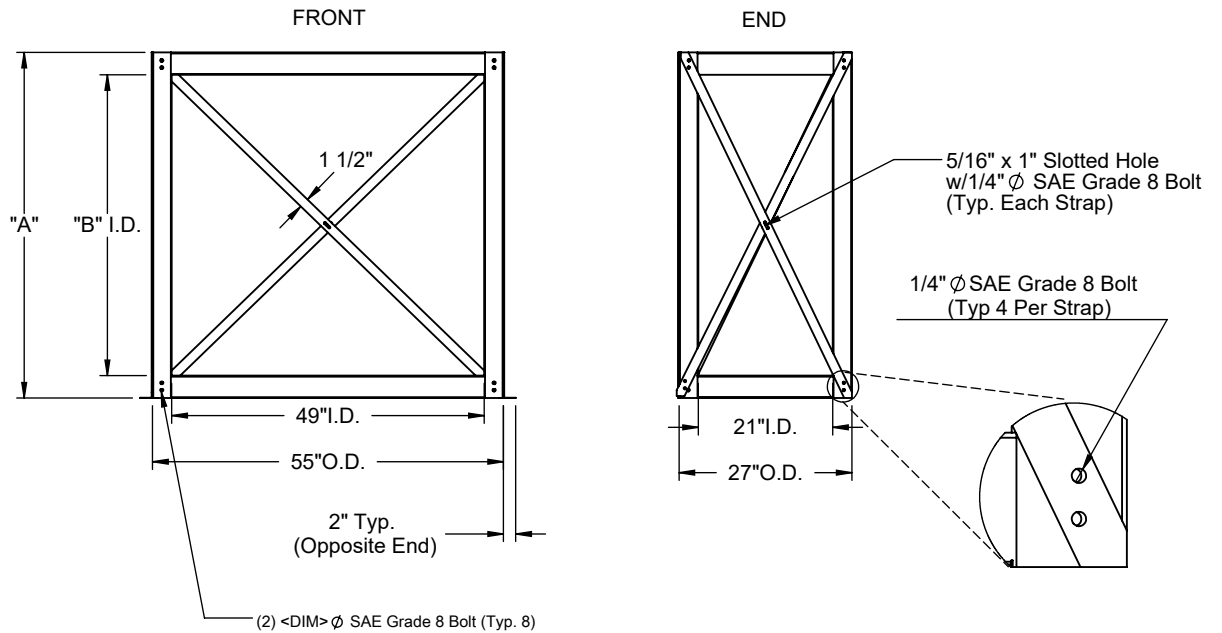
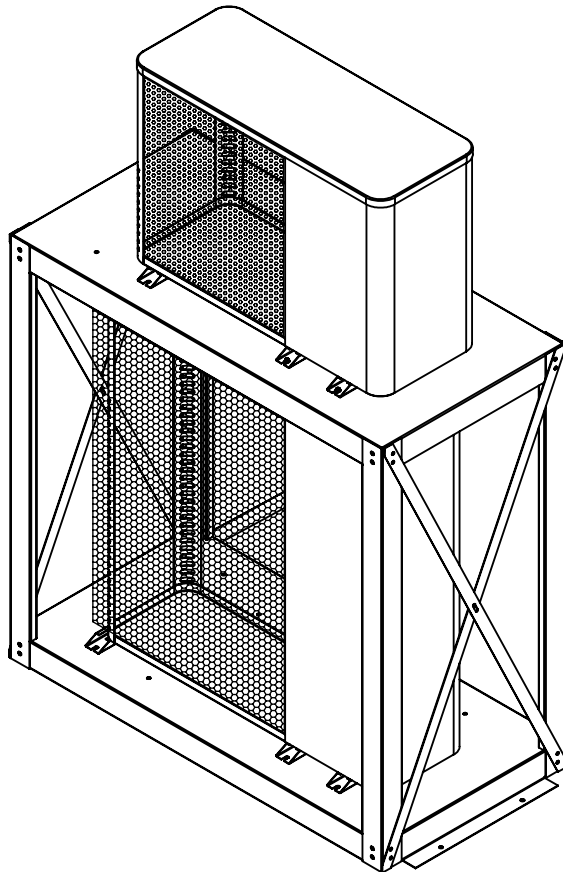

3847 WABASH DRIVE
MIRA LOMA, CA 91725

PHONE (951) 685-1101
FAX (619) 872-9799

SUBMITTED TO: _____
 COMPANY: _____
 JOB NAME: _____
 EQUIPMENT: _____
 NOTES: _____

FORM NO: _____
 -
 DATE: 8/31/2021

PART NUMBER: STACKSAMAM SERIES
 REV: M
 DRAWN BY: CNG