

FEATURES

- Simple bolt on assembly. (All bolt connections are pre-threaded.)
- 16 Ga. GS90 Galvanized Steel
- Foot mount bolt locations are pre-punched for simple bolt on anchoring.

STACKING RACK FOR SAMSUNG "AC" SERIES CONDENSING UNITS

PROVENT P/N	UNIT	A	B	Wt.
STACKSAMAC-01	AC 018	37"	30"	100 Lbs.
STACKSAMAC-02	AC 024-030	50"	43"	175 Lbs.
STACKSAMAC-03	AC 030-036 (MAX HEAT) AC 036-048	67"	60"	198 Lbs.

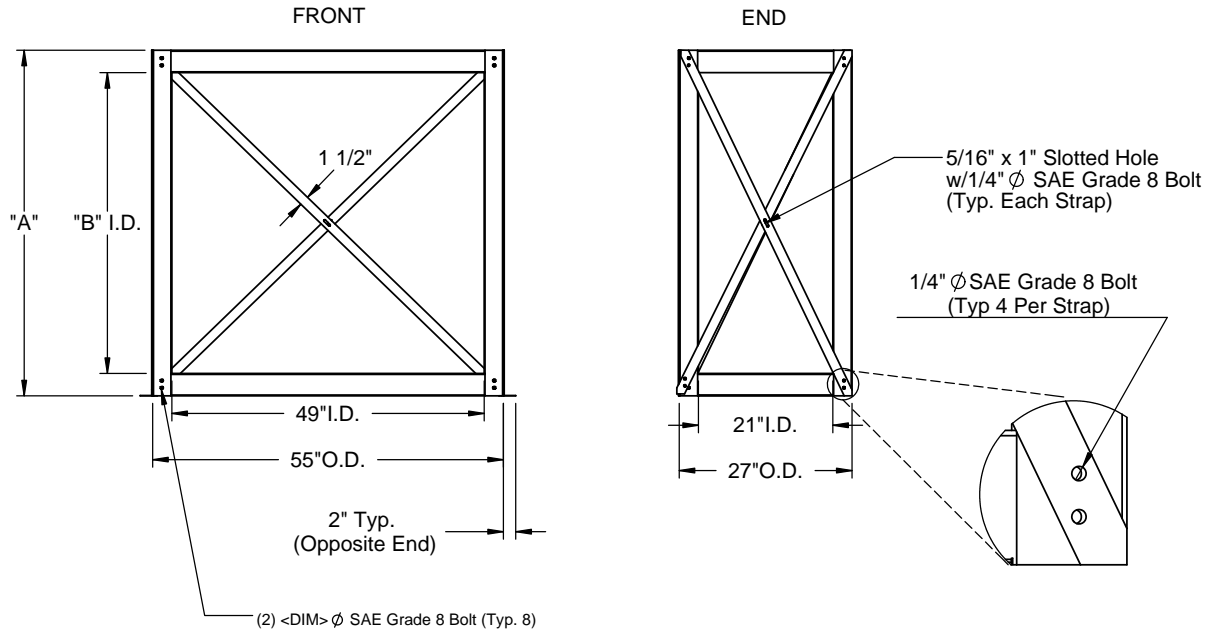
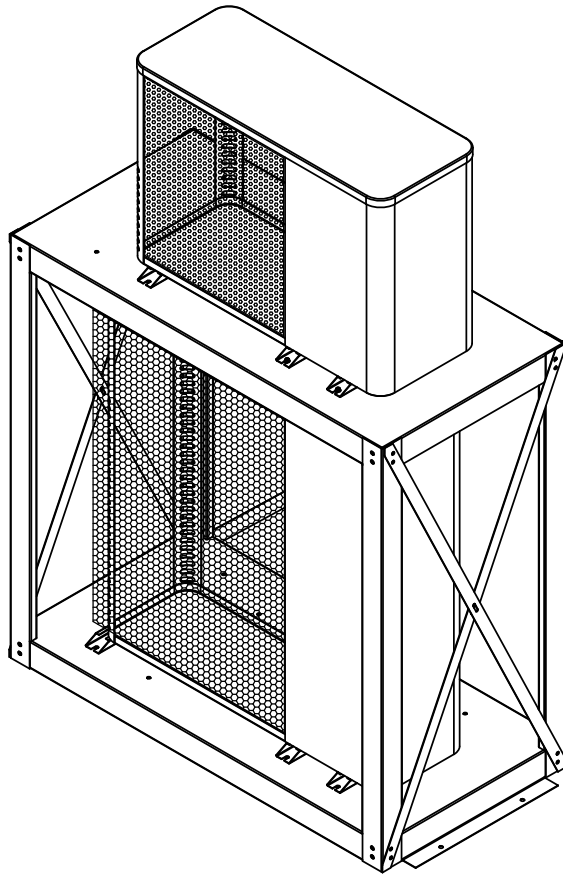

3847 WABASH DR.
MIRA LOMA, CA 91725

PHONE (951) 685-1101
FAX (619) 872-9799

SUBMITTED TO: _____
 COMPANY: _____
 JOB NAME: _____
 EQUIPMENT: _____
 NOTES: _____

FORM NO: _____

PART NUMBER:
STACKSAMAC SERIES

DATE:
2/11/2019

REV:
M1

DRAWN BY:
ALL