

FILTER MIXING BOX FOR MITSUBISHI PEFY-P**NMAU; PEFY-P**NMSU; PEAD-A* UNITS

FEATURES:

- 20 Ga. factory assembled.
- Insulation: 1"-1.5 lb. Density
- Title 24 compliant low leak dampers.
- Controls package includes:
 DB Selectable dry bulb
 or
 EN Enthalpy modulating controls.
 Also includes relay signal switch.

**** DAMPER ORIENTATIONS:

- RETURN AIR TOP, OUTSIDE AIR REAR (**RTOR**)
- RETURN AIR BOTTOM, OUTSIDE AIR REAR (**RBOR**)
- RETURN AIR REAR, OUTSIDE AIR TOP (**RROT**)
- RETURN AIR REAR, OUTSIDE AIR BOTTOM (**RROB**)

(ADD TO END OF PART NUMBER AFTER CONTROL SELECTION)

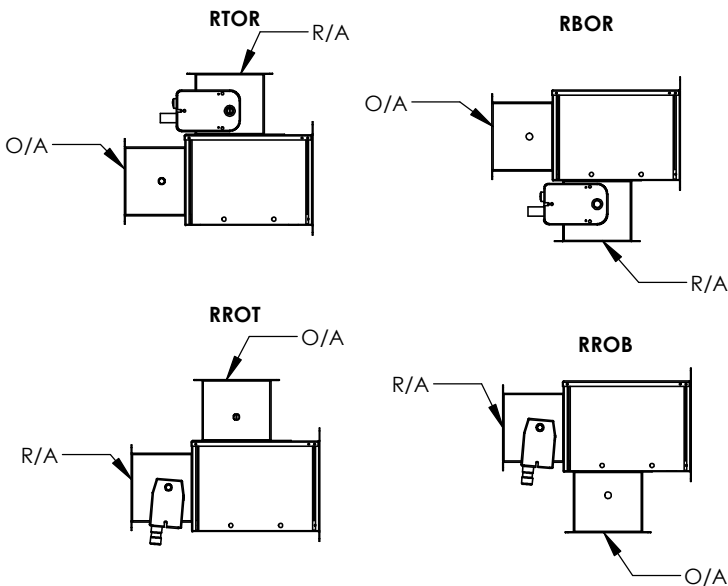

MITSUBISHI UNIT	PART NUMBER	CONTROLS	A	B	C	D	E	EST.WT
PEFY-P06NM*U PEFY-P08NM*U PEFY-P12NM*U	MBPEFYAU0612NC-**** MBPEFYAU0612DB-**** MBPEFYAU0612EN-****	NO CONTROLS DRY BULB ENTHALPY	26"	24-1/2"	8 3/8"	8 3/8"	14-7/8"	68 LBS.
PEFY-P15NM*U PEFY-P18NM*U PEAD-A09 PEAD-A12 PEAD-A15 PEAD-A18	MBPEFYAU1518NC-**** MBPEFYAU1518DB-**** MBPEFYAU1518EN-****	NO CONTROLS DRY BULB ENTHALPY	33 7/8"	32-3/8"	8 3/8"	8 3/8"	14-7/8"	83 Lbs.
PEFY-P24NM*U PEFY-P27NMAU PEFY-P30NMAU PEAD-A24 PEAD-A30	MBPEFYAU2430NC-**** MBPEFYAU2430DB-**** MBPEFYAU2430EN-****	NO CONTROLS DRY BULB ENTHALPY	41 3/4"	40-1/4"	8 3/8"	8 3/8"	14-7/8"	88 LBS.
PEFY-P36NMAU PEFY-P48NMAU PEAD-A36 PEAD-A42	MBPEFYAU3648NC-**** MBPEFYAU3648DB-**** MBPEFYAU3648EN-****	NO CONTROLS DRY BULB ENTHALPY	53 9/16"	52-1/16"	8 3/8"	8 3/8"	14-7/8"	113 LBS.
PEFY-P54NMAU	MBPEFYAU54NC-**** MBPEFYAU54DB-**** MBPEFYAU54EN-****	NO CONTROLS DRY BULB ENTHALPY	61 1/2"	60"	8 3/8"	8 3/8"	14-7/8"	122 LBS.

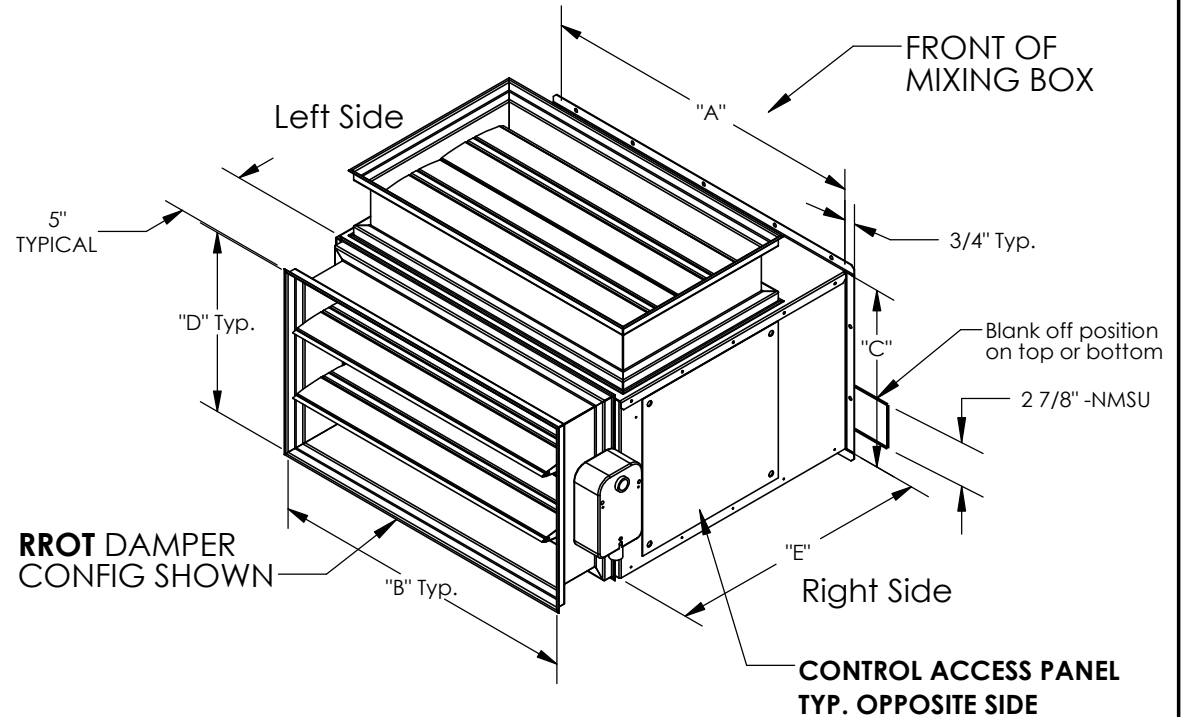

3847 WABASH DR.
MIRA LOMA, CA 91725

PHONE (951) 685-1101
FAX (619) 872-9799

SUBMITTED TO: _____
 COMPANY: _____
 JOB NAME: _____
 EQUIPMENT: _____
 NOTES: _____

FORM NO:
MBPEFY-102

DATE:
7/22/2020

PART NUMBER:
MBPEFY*U SERIES

REV:
11

DRAWN BY:
JG