

FEATURES

- Roof curb perimeter made of 16 ga. galvanized steel.
- Gasketing package provided.
- Heat treated wood nailer provided.
- Pitched, adjustable pitch/adjustable height, welded, different height, isolation and calculated curbs are available.

NOTES

- Attach ductwork to roof curb. Flanges of duct rest on top of the curb. Support ductwork below the curb.

WELDED ROOF CURB FOR ALLIED UNITS

LGH/LCH 092-120H, 150S
KGA/KCA/KHA 092-150S

PROVENT P/N	A	EST. WEIGHT
CBWBBX08	8"	77 Lbs.
CBWBBX11	11"	97 Lbs.
CBWBBX14	14"	111 Lbs
CBWBBX24	24"	158 Lbs

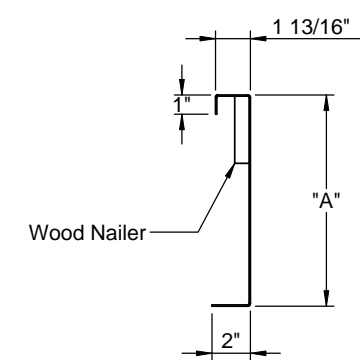
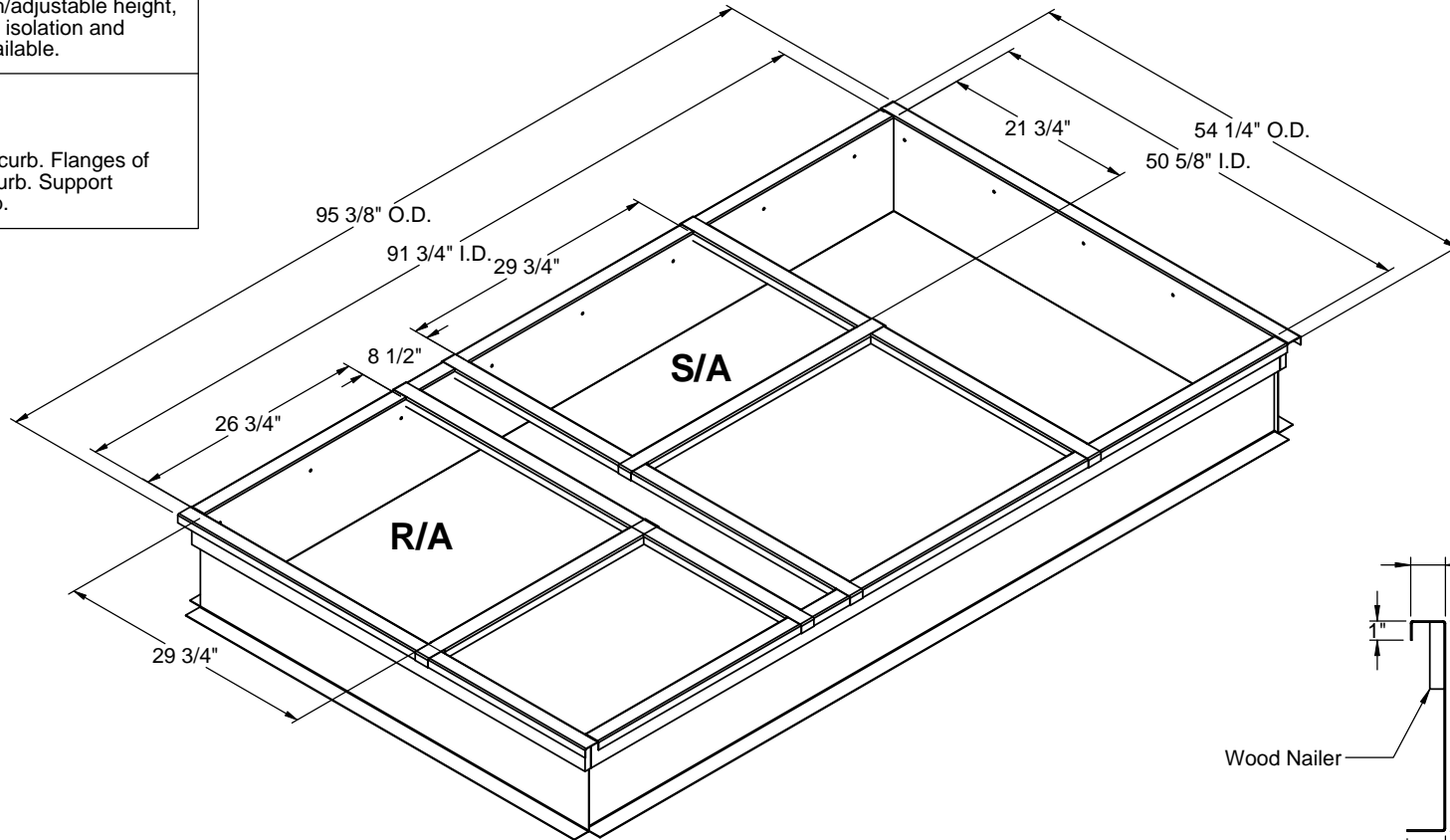

CROSS SECTION DETAIL



3847 WABASH DR.
MIRA LOMA, CA 91725

PHONE (951) 685-1101
FAX (619) 872-9799

SUBMITTED TO: _____
COMPANY: _____
JOB NAME: _____
EQUIPMENT: _____
NOTES: _____

FORM NO:
CBW-203

DATE:
8/23/2013

PART NUMBER:
CBWBBX SERIES

REV:
-

DRAWN BY:
CNG