

FEATURES

- Roof curb perimeter made of 16 ga. galvanized steel.
- Gasketing package provided.
- Heat treated wood nailer provided.
- Corner flanges are pre-threaded for easy bolt on assembly.
- Pitched, adjustable pitch/adjustable height, welded, different height, isolation and calculated curbs are available.

NOTES

- Attach ductwork to roof curb. Flanges of duct rest on top of the curb. Support ductwork below the curb.

KNOCK-DOWN ROOF CURBS FOR ALLIED UNITS

LGH/LCH 156-240H, 300S
KGA/KCA 180-300S, KHA 180-240S

PROVENT P/N	A	EST. WEIGHT
CBKDCBX08	8"	107 Lbs.
CBKDCBX11	11"	130 Lbs.
CBKDCBX14	14"	153 Lbs.
CBKDCBX24	24"	227 Lbs.

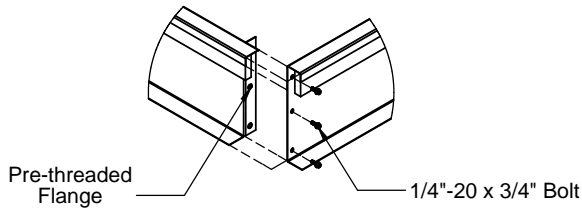
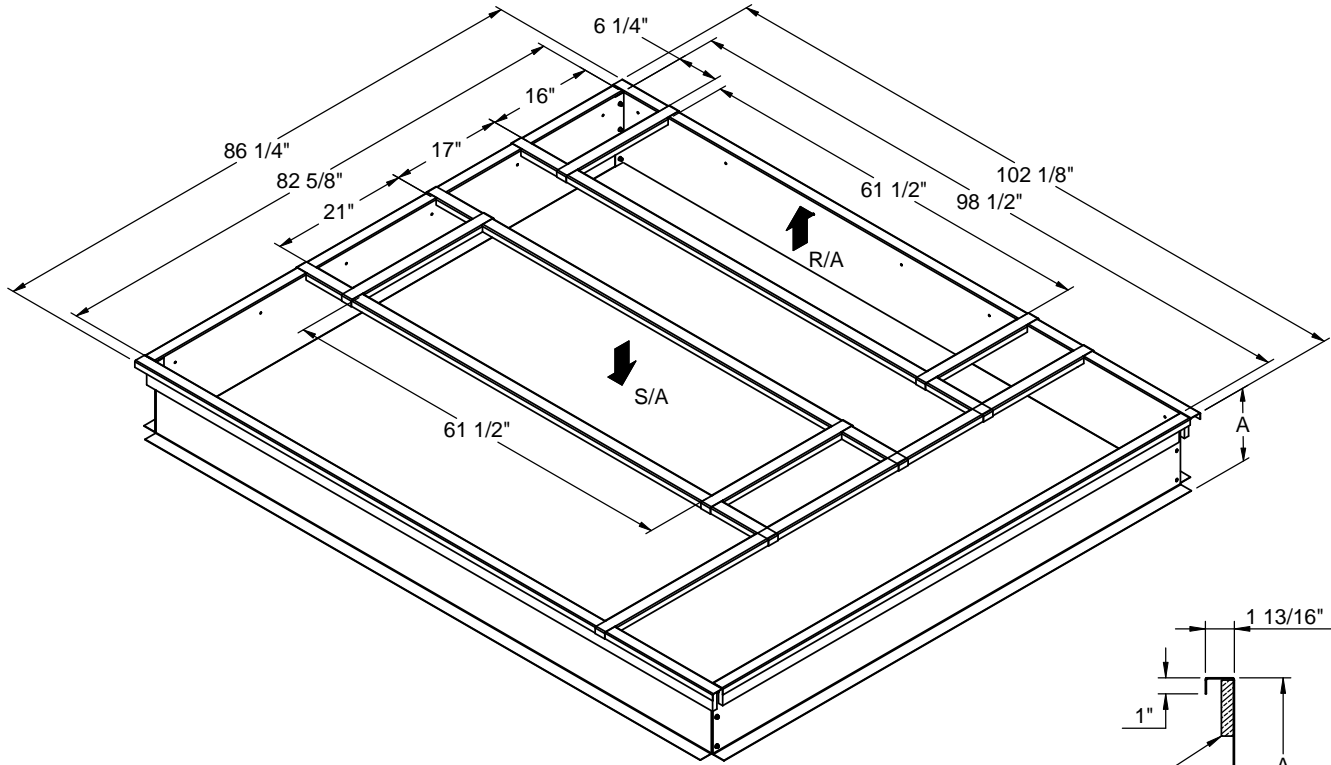

CORNER DETAIL

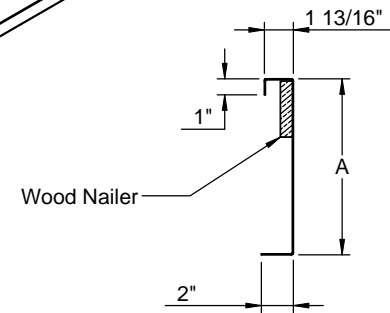

CROSS SECTION DETAIL



3847 WABASH DR.
MIRA LOMA, CA 91725

PHONE (951) 685-1101
FAX (619) 872-9799

SUBMITTED TO: _____
COMPANY: _____
JOB NAME: _____
EQUIPMENT: _____
NOTES: _____

FORM NO:
CBKD-207

PART NUMBER:
CBKDCBX Series

DATE:
8/5/2013

REV:
3

DRAWN BY:
CNG