

FEATURES

- Simple bolt on assembly. (All bolt connections are pre-threaded.)
- 16 Ga. Galvanized Steel
- Designed for all unit size configurations.
- Foot mount bolt locations are pre-punched for simple bolt on anchoring.

CALCULATED STACKING RACK FOR YORK UNITS

PROVENT P/N Wt.

YCHD/TCHD 18-60

STACKYCHD1860 153 Lb

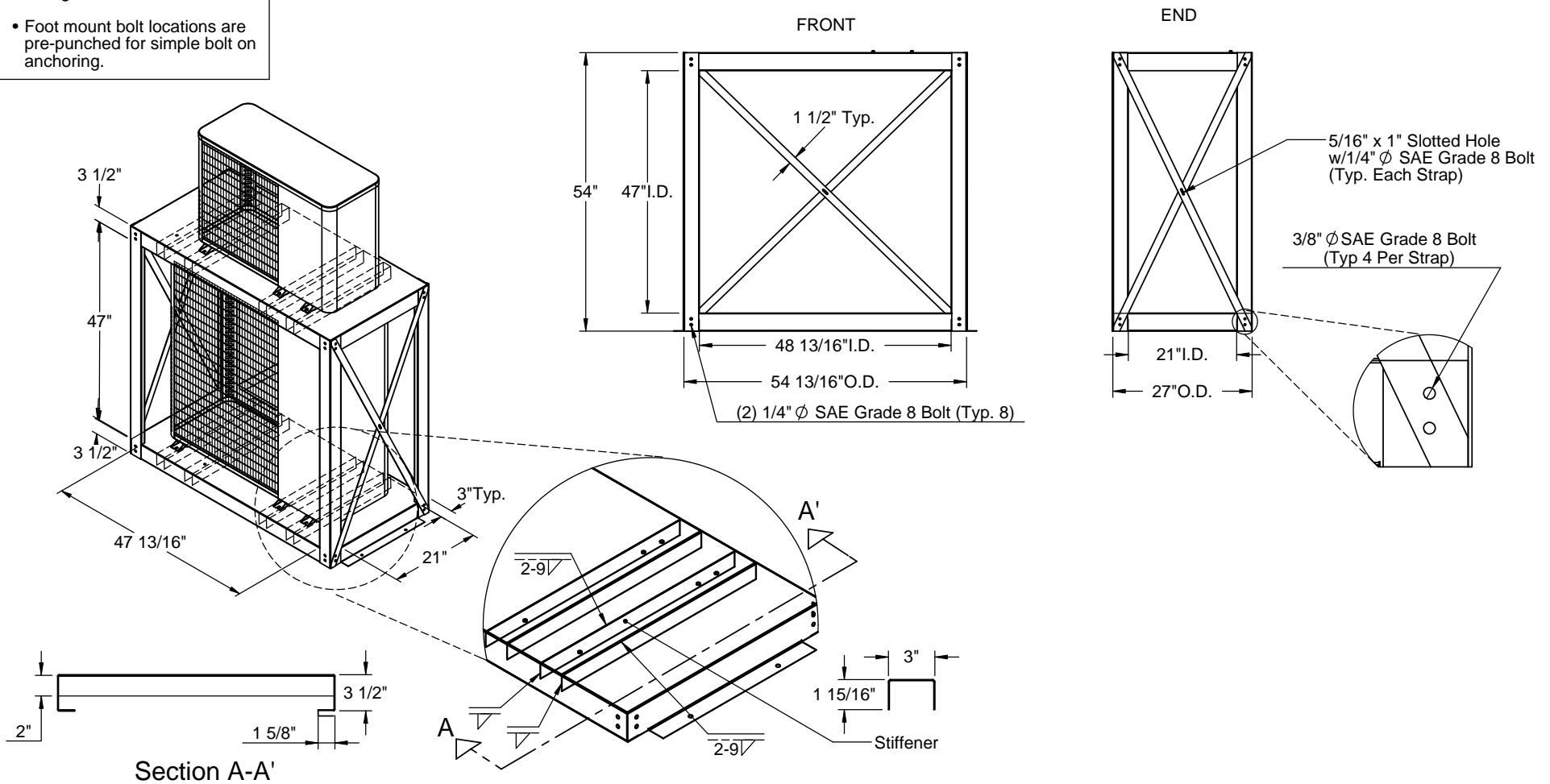

**3847 WABASH DRIVE
MIRA LOMA, CA 91752**

**PHONE (951) 685-1101
FAX (619) 872-9799**

SUBMITTED TO: _____
 COMPANY: _____
 JOB NAME: _____
 EQUIPMENT: _____
 NOTES: _____

FORM NO: _____
 -

DATE: 5/29/2014

PART NUMBER: STACKTCHD1860

REV: -

DRAWN BY: CNG