

FEATURES	DOWN DISCHARGE AXIAL POWER EXHAUST ECONOMIZER FOR YORK UNITS						ProVent P/N				
	PCG4B, PCE4B 048-060/ PHE4B, PHG4B 036-060						CONSTANT VOLUME	MODULATING			
	<ul style="list-style-type: none"> <li>Includes fully modulating economizer. (See Form ECO-501 for Economizer Specs).</li> <li>CO2 controller standard on economizer. Space or duct mounted CO2 sensor provided as option:               <ul style="list-style-type: none"> <li>CO2WM - Wall Mount With LED</li> <li>CO2DM - Duct Mount</li> </ul> </li> <li>LEED economizer option.</li> <li>Direct drive axial fan.</li> <li>Modulating option includes fully programmable (factory set) variable frequency drive controlled by a differential pressure transducer designed to continuously monitor space pressure.</li> </ul>	VOLTAGE	External Static (in. W.G)				FLA	HP	Wt	PEDALXLDDB06C 208/230V 1Ph Selectable Dry Bulb	PEDALXLDDB06M 208/230V 1Ph Selectable Dry Bulb
230V/1Ph			0.1	0.2	0.3	0.4				0.5	2.5
230V/3Ph		1,500	1,375	1,250	1,150	900	2.5	PEDALXLDDB25C 208/230V 3Ph Selectable Dry Bulb	PEDALXLDDB25M 208/230V 3Ph Selectable Dry Bulb		
460V/3Ph							0.8	PEDALXLEN25C 208/230V 3Ph Enthalpy	PEDALXLEN25M 208/230V 3Ph Enthalpy		
	PLEASE NOTE:								PEDALXLDDB46C 460V 3Ph Selectable Dry Bulb	PEDALXLDDB46M 460V 3Ph Selectable Dry Bulb	
									PEDALXLEN46C 460V 3Ph Enthalpy	PEDALXLB1 EN46M 460V 3Ph Enthalpy	
									<b>Note: For factory installed LEED economizer / power exhaust option, part number, FLOWECLXL , must be added.</b>		

**LEED ECONOMIZER / POWER EXHAUST OPTION**

- ProVent P/N: FLOWECLXL
- Outside air measurement for dilution utilizing thermal dispersion technology and ASHRAE 62.1 compliant. Provides LEED credit by supplying feedback on ventilation system performance ensuring that the ventilation system maintains design requirements.
- Factory installed onto economizer/power exhaust standard.
- Provides analog outputs for BMS, visual or audible alert, and generates an alarm when conditions vary by 10% or more of set point.

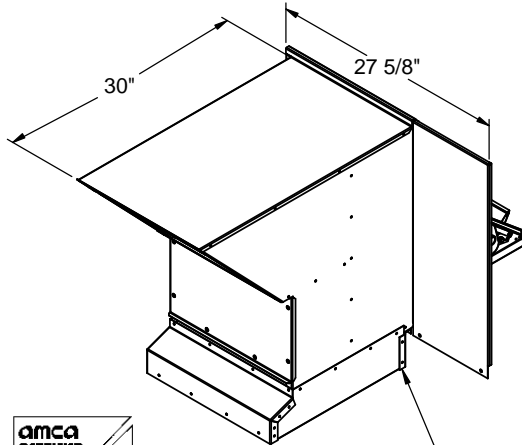
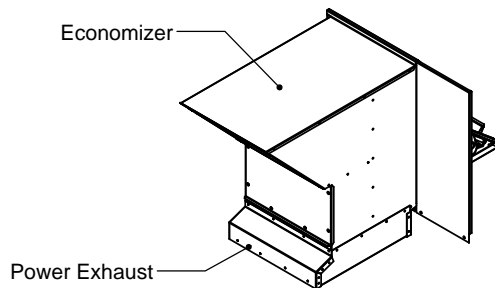

Only Ruskin Company Model CD-60 is AMCA Certified

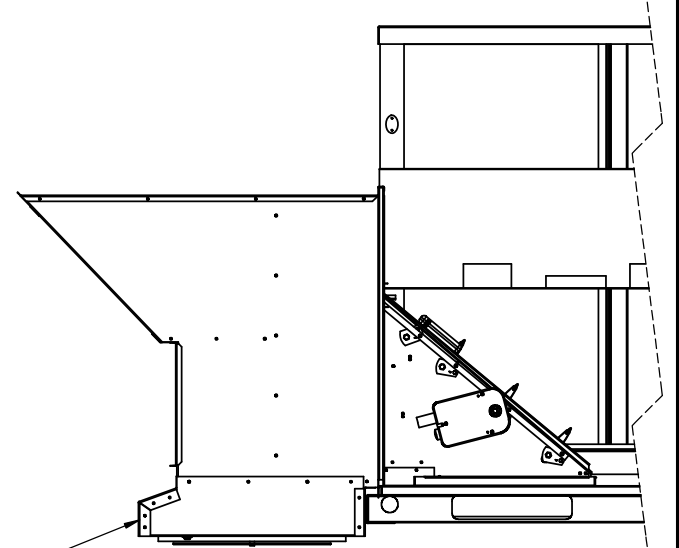

3847 WABASH DR.  
MIRA LOMA, CA 91725

PHONE (951) 685-1101  
FAX (619) 872-9799

SUBMITTED TO: \_\_\_\_\_  
 COMPANY: \_\_\_\_\_  
 JOB NAME: \_\_\_\_\_  
 EQUIPMENT: \_\_\_\_\_  
 NOTES: \_\_\_\_\_

FORM NO:  
PE-78

PART NUMBER:  
PEDALXL SERIES

DATE:  
1/18/2016

REV:  
-

DRAWN BY:  
FMM