

Before Starting Installation

Warning

Severe injury can result from incorrect servicing. Only qualified HVAC service personnel should install, troubleshoot, repair or service HVAC and related HVAC equipment.

Always disconnect power before servicing. Please note some installation configurations may have more than one disconnect.

Important

Always follow all local building electrical codes.

		1½ to 5 Tons						
Voltage	ProVent P/N	External Static Pressure (Inch W.G.)					FLA	Hp
		0.1	0.2	0.3	0.4	0.5		
208/230V/1Ph	PEHAAFF1860DB06C PEHAAFF1860EN06C	1,500 CFM	1,375 CFM	1,250 CFM	1,150 CFM	900 CFM	2.5	0.5
208/230V/3Ph	PEHAAFF1860DB25C PEHAAFF1860EN25C							
460V/3Ph	PEHAAFF1860DB46C PEHAAFF1860EN46C						1.3	

PARTS INCLUDED	QTY.
#10 x 1/2" Sheet Metal Screw	11

Installation Instructions

1. Install economizer per instructions.
2. Cut a 8" x 18-3/16" opening on the side of the return air duct. (ILL. 1)
3. Pull the power cord and the 24V yellow control wire leads located on the face of the economizer return air damper thru the opening cut for the power exhaust. Connect the molex plug on the power cord to the power exhaust power cord. Connect the control wire leads to the yellow leads in the power exhaust cabinet. (ILL. 1)

See wiring diagram notes and follow all electrical codes for connection. (ILL. 2, 3, 4)

4. Install power exhaust on the return air duct and secure with #10 screws provided.

Based on return air duct supports, power exhaust may require field support. (ILL. 1)

ILL. 1

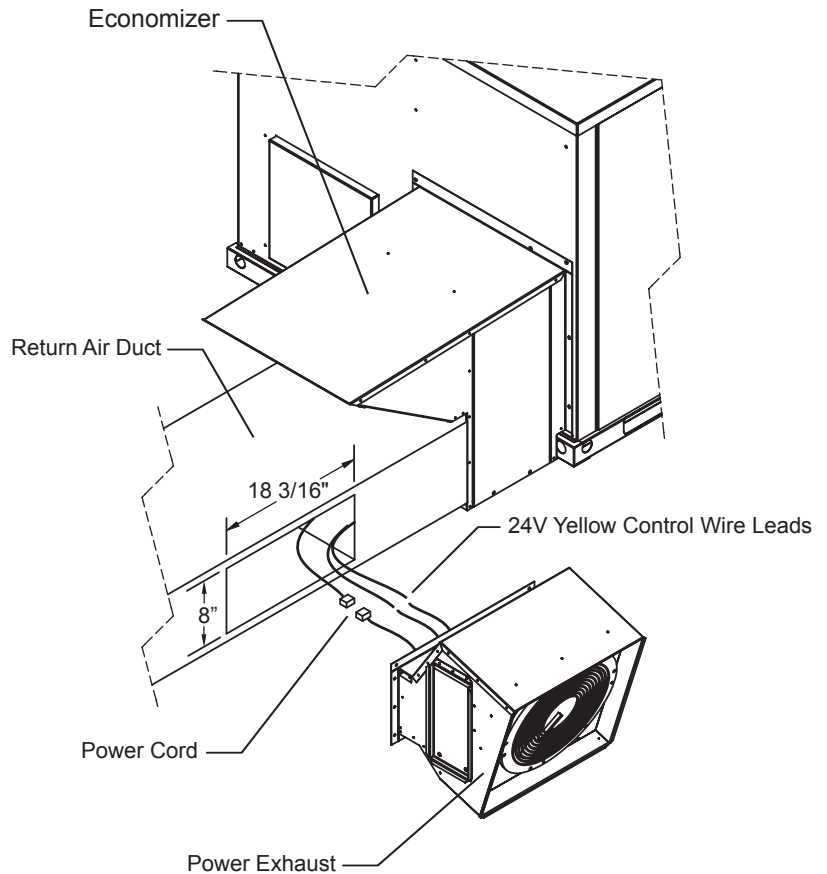

ILL. 2 - Power Exhaust Wiring Diagram 460V/3Ph

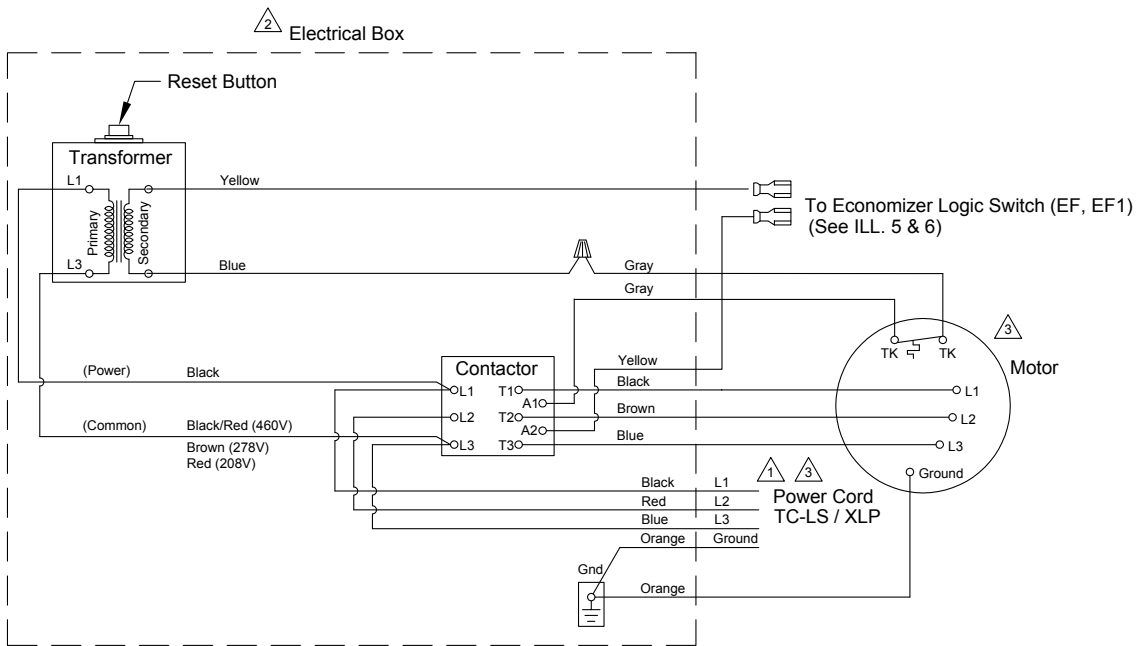

⚠ Power Supply. Provide disconnect means and circuit protection as required. See power exhaust name plate for electrical ratings. If local codes allow connecting to the HVAC unit power, make sure the disconnect and incoming wiring are sized to handle the load of both the HVAC unit and the power exhaust.

To determine MCA with power exhaust: $\text{New MCA} = \text{MCA of Unit Only} + \text{MCA of Power Exhaust}$

⚠ Transformer, contactor and fuses are to be in a NEMA type electrical enclosure.

⚠ For voltage, refer to label on exterior of power exhaust cabinet.

ILL. 3 - Power Exhaust Wiring Diagram 230V/3Ph

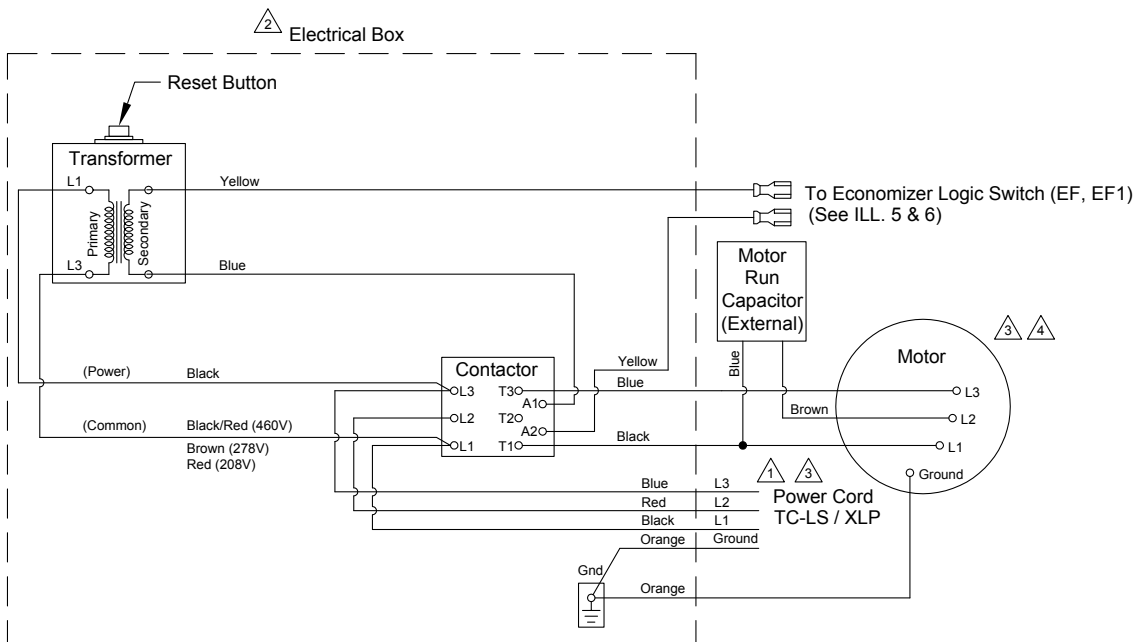

⚠ Power Supply. Provide disconnect means and circuit protection as required. See power exhaust name plate for electrical ratings. If local codes allow connecting to the HVAC unit power, make sure the disconnect and incoming wiring are sized to handle the load of both the HVAC unit and the power exhaust.

To determine MCA with power exhaust: $\text{New MCA} = \text{MCA of Unit Only} + \text{MCA of Power Exhaust}$

⚠ Transformer, contactor and fuses are to be in a NEMA type electrical enclosure.

⚠ For voltage, refer to label on exterior of power exhaust cabinet.

⚠ Motor supplied with internal thermal protection.

ILL. 4 - Power Exhaust Wiring Diagram 230V/1Ph

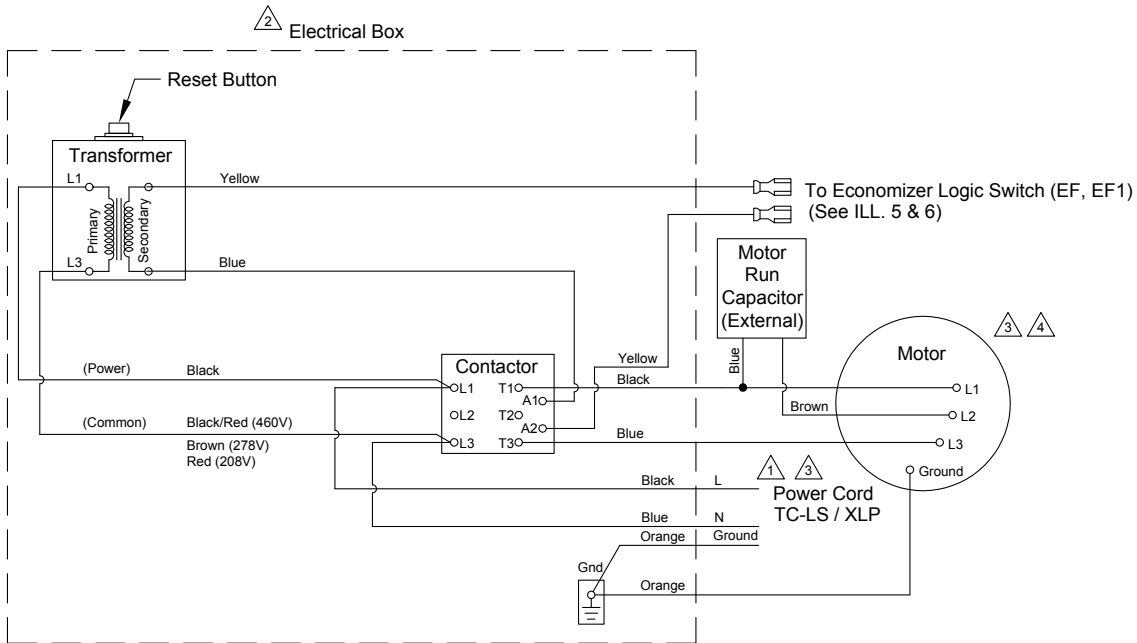

⚠ Power Supply. Provide disconnect means and circuit protection as required. See power exhaust name plate for electrical ratings. If local codes allow connecting to the HVAC unit power, make sure the disconnect and incoming wiring are sized to handle the load of both the HVAC unit and the power exhaust.

To determine MCA with power exhaust: $\text{New MCA} = \text{MCA of Unit Only} + \text{MCA of Power Exhaust}$

⚠ Transformer, contactor and fuses are to be in a NEMA type electrical enclosure.

⚠ For voltage, refer to label on exterior of power exhaust cabinet.

⚠ Motor supplied with internal thermal protection.

Example: With a unit that has MCA=22.5 amps and MOCP=30 amps,

New MCA = 22.5 amps + 3 amps (example for power exhaust) = 25.5 amps

If New MCA is less than MOCP for the HVAC unit, you can tie the power wire to the HVAC contactor terminal strip, **if local code allows**. Make sure tap off terminal block is capable for handling more than one unit.

If new MCA is greater than MOCP or local code requires, you must run power wire for the power exhaust to an external disconnect. Make sure the disconnect is sized properly for the power from the power exhaust as well as the HVAC unit.