

FEATURES:

- Painted hood and panel match factory color.
- Designed for unit mounted down discharge and duct mounted horizontal discharge.
- Includes gravity backdraft damper.
- Insulated panel.

0-35% OUTSIDE AIR PACKAGE FOR YORK UNITS

PCG4B, PCE4B 048-060 / PHE4B, PHG4B 036-060

ProVent P/N

WEIGHT

OALXL35

7 Lbs.

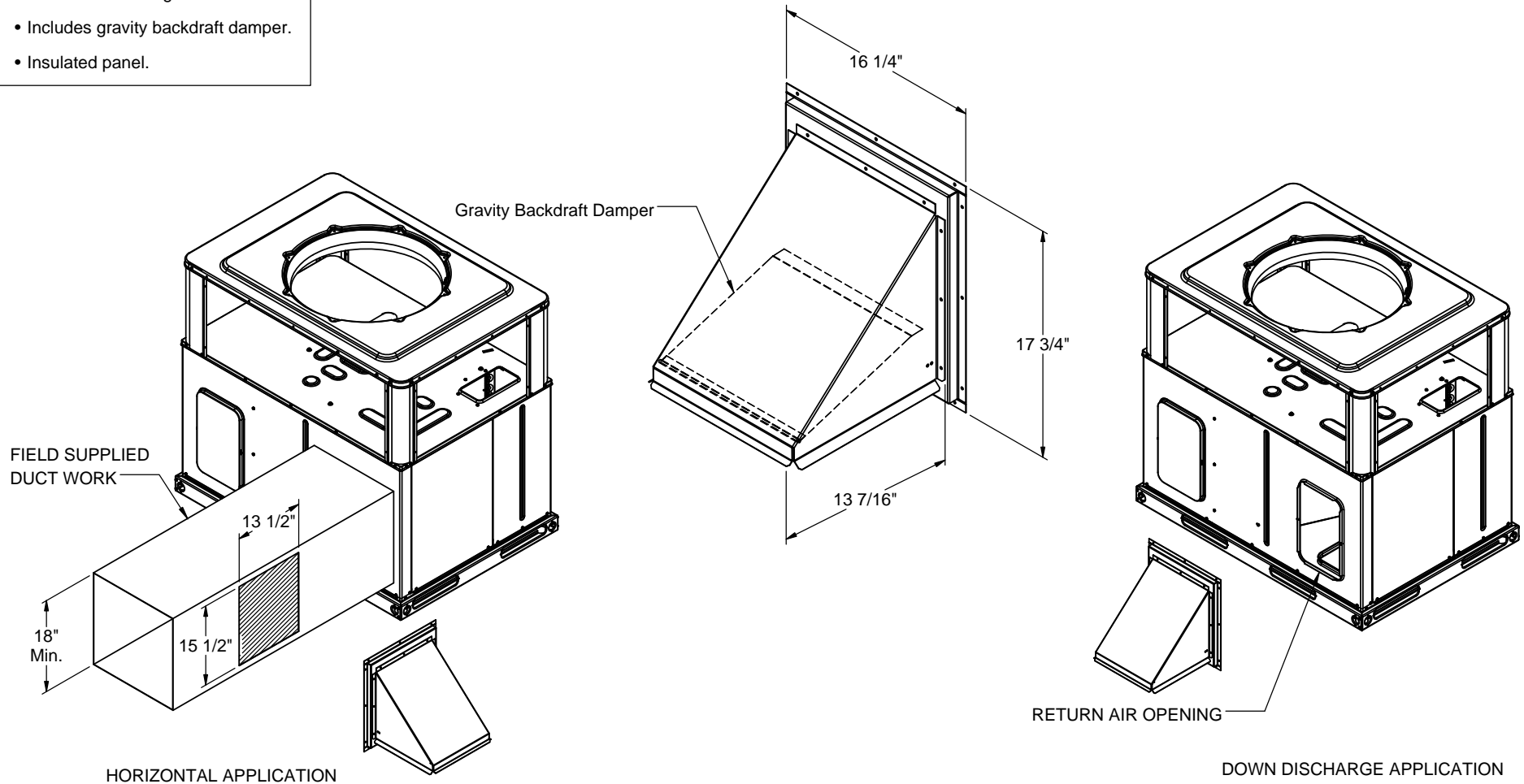

3847 WABASH DRIVE
MIRA LOMA, CA 91752

PHONE (951) 685-1101
FAX (619) 872-9799

SUBMITTED TO: _____
COMPANY: _____
JOB NAME: _____
EQUIPMENT: _____
NOTES: _____

FORM NO:

OA-34

DATE:
9/11/2015

REV:
-

DRAWN BY:
CNG