

FEATURES	0-100% 2 POSITION OFFERING FOR YORK UNITS:	PROVENT P/N	DESCRIPTION	Wt.
		<ul style="list-style-type: none"> <li>Built in damper position limit stop standard. (Not needed with CO2 capable offering).</li> <li>CO2 capable model includes CO2 controller standard.</li> <li>Space or duct mounted CO2 sensor provided as option: <ul style="list-style-type: none"> <li>CO2WM - Wall / Space Mount w/LED display.</li> <li>CO2DM - Duct Mount.</li> </ul> </li> <li>Belimo actuator standard.</li> <li>Stainless steel low leak damper side seals.</li> <li>External linkage system.</li> <li>Mechanically secured upgraded outside air intake filter.</li> <li>Horizontal or down discharge. (Horizontal mounts on duct work).</li> </ul>	DNQ/DNY/DNZ/DEQ/DEZ/BHQ/BHX/BHZ 024-060 DNX/DEX 024-060, DEY 060	
		OA2POAFF1860100VCO2	OUTSIDE AIR SELECTABLE 2 POSITION CO2 CAPABLE (0-100% O/A VARIABLE CO2 CAPABLE)	

**LEED O/A DAMPER OPTION**

- ProVent P/N: FLOWECAFF1860
- Outside air measurement for dilution utilizing thermal dispersion technology and ASHRAE G2.1 2007 compliant. Provides LEED credit by supplying feedback on ventilation system performance ensuring that the ventilation system maintains design requirements.
- Factory installed onto economizer standard.
- Provides analog outputs for BMS, visual or audible alert, and generates an alarm when conditions vary by 10% or more of set point.

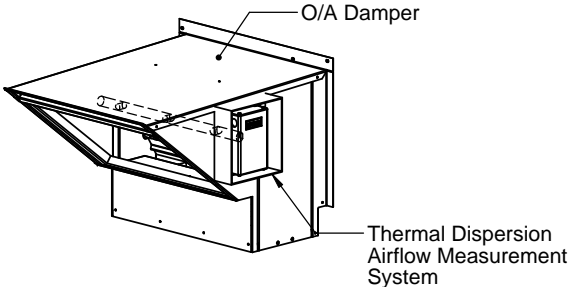

O/A Damper

Thermal Dispersion Airflow Measurement System

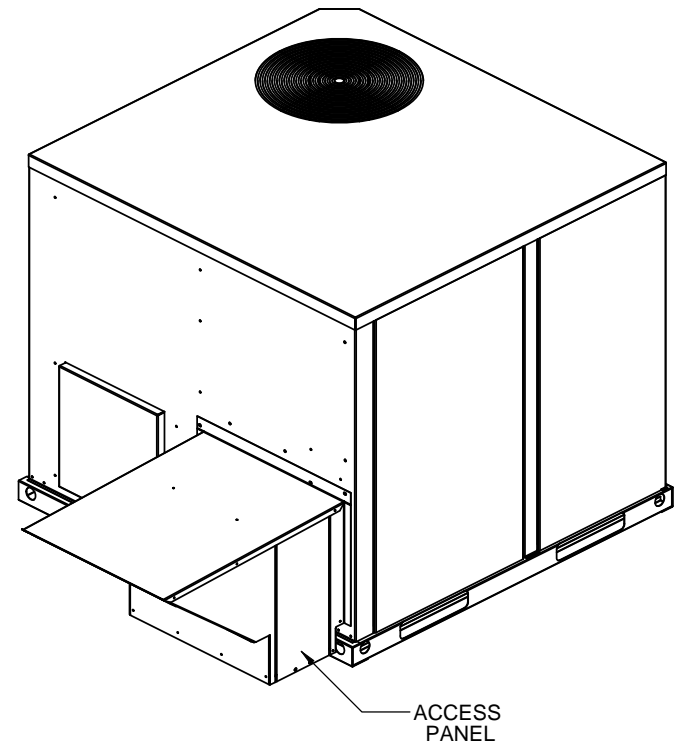
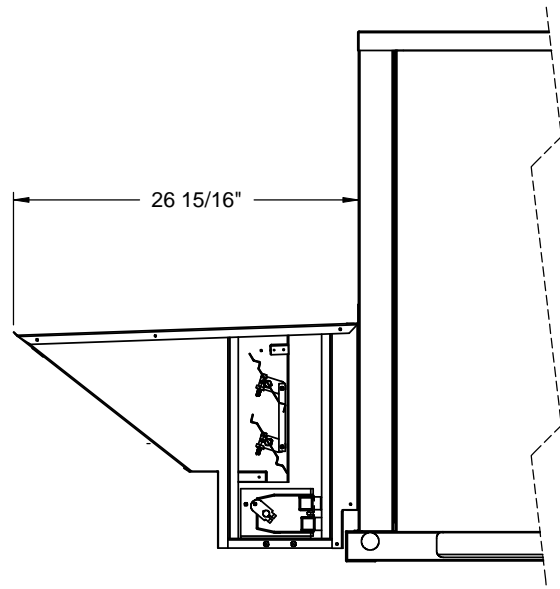

	<b>3847 WABASH DR. MIRA LOMA, CA 91725</b>  <b>PHONE (951) 685-1101 FAX (619) 872-9799</b>	<b>SUBMITTED TO:</b> _____ <b>COMPANY:</b> _____ <b>JOB NAME:</b> _____ <b>EQUIPMENT:</b> _____ <b>NOTES:</b> _____	<b>FORM NO:</b> OA-01	<b>PART NUMBER:</b> OA2POAFF SERIES
			<b>DATE:</b> 8/25/2011	<b>REV:</b> 2