

**FEATURES:**

- CA Title 24 Compliant.
- Factory assembled.
- Galvanized steel construction.
- AMCA certified CD-60 Airfoil dampers blades.
- Meets leakage as required by ASHRAE 90.1
- Fully insulated.
- Low leak dampers.
- Direct coupled actuator.
- Controls package:
  - Includes dry bulb or enthalpy fully modulating controls w/relay signal switch.
  - Specific control type: Add the two digits below to the Part Number:
    - DB** For dry bulb control.
    - EN** For enthalpy control.

**DAMPER MIXING BOXES FOR YORK AIR HANDLES**

Example Shown  
P/N: MB-AH\*\*\*.TBE

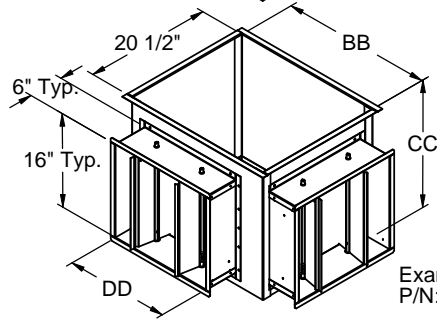
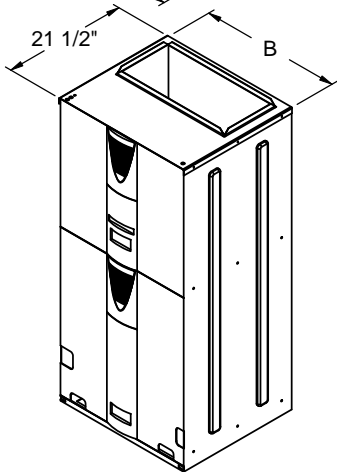
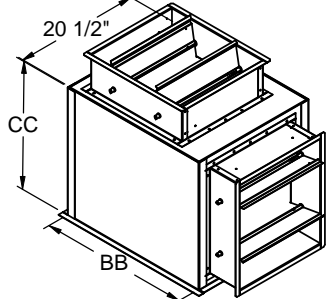

Example Shown  
P/N: MB-AH\*\*\*.BFA

UNIT SIZE	PART NUMBER	CONTROL TYPE	B	BB	CC	DD	EST. WT
AVY24B*21 AH*18-30B*21 AHR18-36B3**21 F4FP024-030* F*R*018-036RC F2F*018-036RC F3F*018-036RC MA08B M*12B	MB-AHB-AC-***	ACTUATOR ONLY	18"	16 1/2"	14" or 20"	10"	65 LBS.
	MB-AHB-DB-***	MODULATING CONTROLS WITH SELECTABLE DRY BULB					
	MB-AHB-EN-***	MODULATING CONTROLS WITH ENTHALPY					
AVY36C*21 AH*36-42C*21 AHR42C3**21 F4FP036-042* F*R*036(RP)-042 F2F*036(RP)-042 F3F*036(RP)-042 M*16C	MB-AHC-AC-***	ACTUATOR ONLY	21 1/2"	20"	18" or 20"	14"	70 LBS.
	MB-AHC-DB-***	MODULATING CONTROLS WITH SELECTABLE DRY BULB					
	MB-AHC-EN-***	MODULATING CONTROLS WITH ENTHALPY					
*VY48-60D*21 *HP48-60D*21 *AHX48D*21 F4FP045-060* F5FP045-060* F*R*045-060 F2F*045-060 F3F*045-060	MB-AHD-AC-***	ACTUATOR ONLY	24"	23"	20" or 22"	18"	75 LBS.
	MB-AHD-DB-***	MODULATING CONTROLS WITH SELECTABLE DRY BULB					
	MB-AHD-EN-***	MODULATING CONTROLS WITH ENTHALPY					
AHX60D*21 AHR48-60D3**21 MA14D MA20D MV12D MV20D	MB-AHE-AC-***	ACTUATOR ONLY	24 1/2"	23 1/2"	20" or 22"	18"	75 LBS.
	MB-AHE-DB-***	MODULATING CONTROLS WITH SELECTABLE DRY BULB					
	MB-AHE-EN-***	MODULATING CONTROLS WITH ENTHALPY					

**Mixing Box Position**

- T- Top mounted.
- B- Bottom mounted.

**Damper Locations**

A, B, F, D, or E.  
Positions with first position as Return.

(Added to end of part #)

**B-Bottom mounted.**

**T-Top mounted.**

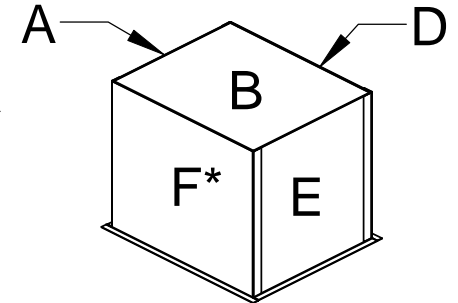
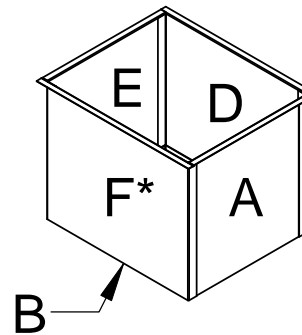

\* F Position represents front of Mixing Box which will always match to front of Air Handler.



3847 WABASH DR.  
MIRA LOMA, CA 91725

PHONE (951) 685-1101  
FAX (619) 872-9799

SUBMITTED TO: \_\_\_\_\_  
COMPANY: \_\_\_\_\_  
JOB NAME: \_\_\_\_\_  
EQUIPMENT: \_\_\_\_\_  
NOTES: \_\_\_\_\_

FORM NO:  
MBAH-01

PART NUMBER:  
-

DATE:  
9/19/2014

REV:  
3

DRAWN BY:  
FMM