

Installation Instructions

1. The top and bottom brackets are configured to accept 1" filters. To configure for 2" filters, remove the angles within the brackets. **(ILL. 1)**
2. Place the bottom bracket into the unit and set within the bottom duct flange. **(ILL. 3)**
3. Remove the far left screw on the front of the heat exchanger plenum and the far left screw on the back of the heat exchanger plenum. **(ILL. 3)**
4. Insert the tab on the side of the bottom bracket into the slot on the top bracket. **(ILL. 2)**
5. Secure the top bracket to the heat exchanger plenum with the screws removed in Step 3. **(ILL. 3)**
6. Slide filters into place.
7. Install strap and set screw. **(ILL. 2)**

ILL. 1

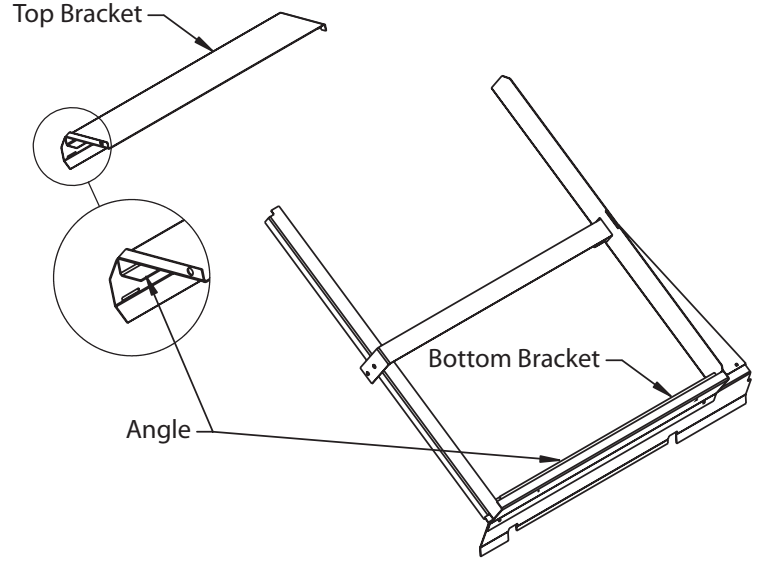

ILL. 2

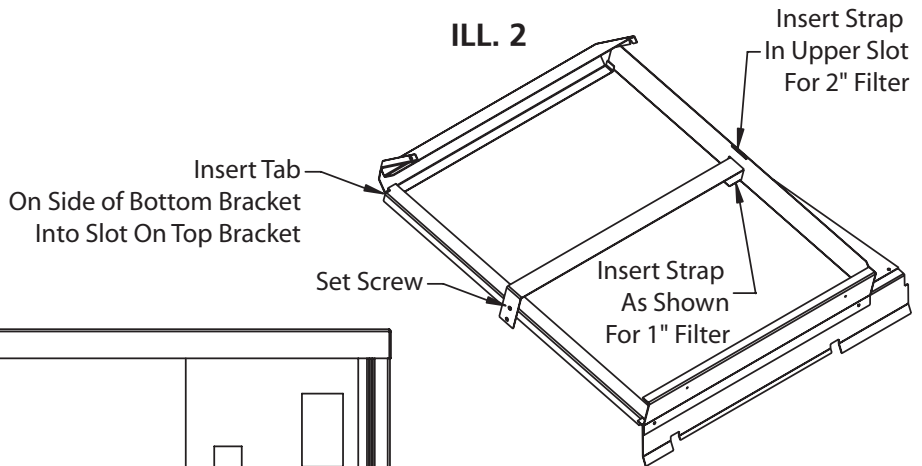

ILL. 3

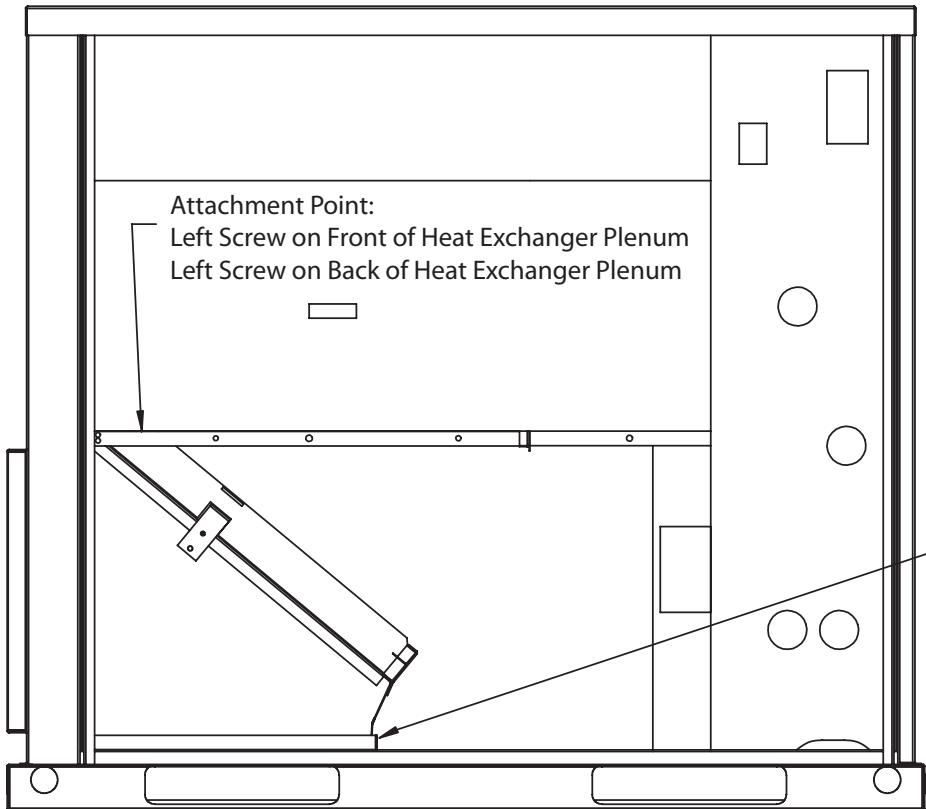

CONTENTS INCLUDED	QTY.
Top Bracket	1
Bottom Bracket	1
11-3/4" x 19-1/2" x 3/4" Filter	2
#10 x 1/2 Sheet Metal Screw	3