

FEATURES

- Direct coupled style actuator standard.
- **CA Title 24 Compliant**
- Stainless steel damper side seals.
- **AMCA certified CD-60 Airfoil dampers blades.**
- **Meets leakage rate as required by ASHRAE 90.1.**
- External linkage system.
- Mechanically secured outside air intake filter.
- Capable of introducing up to 100% outdoor air.
- Metal Filter 19"x 16- 1/16"x 7/8" (exact) included.

FEATURES (When Ordered With Control Options)

- Controls are FDD Compliant.
- Fully modulating damper controls with enthalpy, dry bulb and differential temperature sensor options.
- Selectable economizer changeover temperature set point.
- Requires part number 6210-0010J for Dual Enthalpy.
- CO2 controller standard.
Wall or duct mounted CO2 sensor provided as option:
CO2WM - Wall Mount
CO2DM - Duct Mount

LEED ECONOMIZER OPTION

- ProVent P/N: FLOWECAFF1860
- Outside air measurement for dilution utilizing thermal dispersion technology and ASHRAE 62.1 compliant. Provides LEED credit by supplying feedback on ventilation system performance ensuring that the ventilation system maintains design requirements.
- Factory installed onto economizer standard.
- Provides analog outputs for BMS, visual or audible alert, and generates an alarm when conditions vary by 10% or more of set point.

Economizer

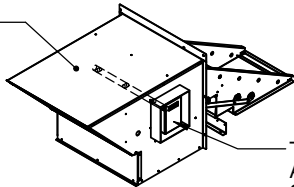

Thermal Dispersion Airflow Measurement System

VERTICAL ECONOMIZER FOR YORK UNITS

**DNQ/DNY/DNZ/DEQ/DEZ/BHQ/BHX/BHZ 024-060
DNX/DEX 024-060, DEY 060**

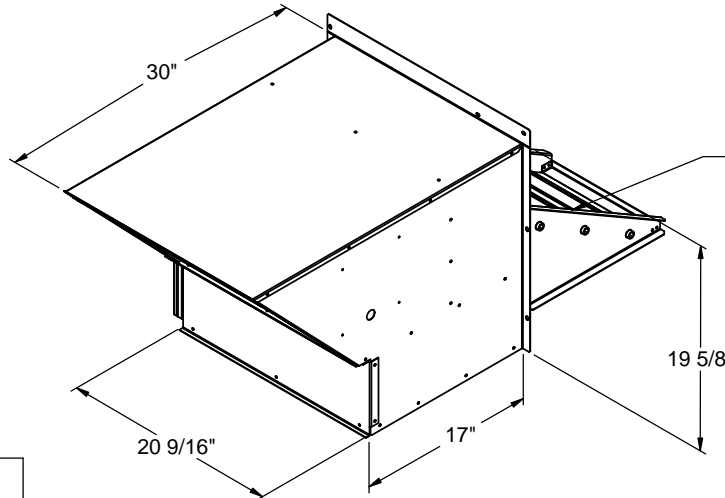

Multi-blade damper stays flush inside economizer housing

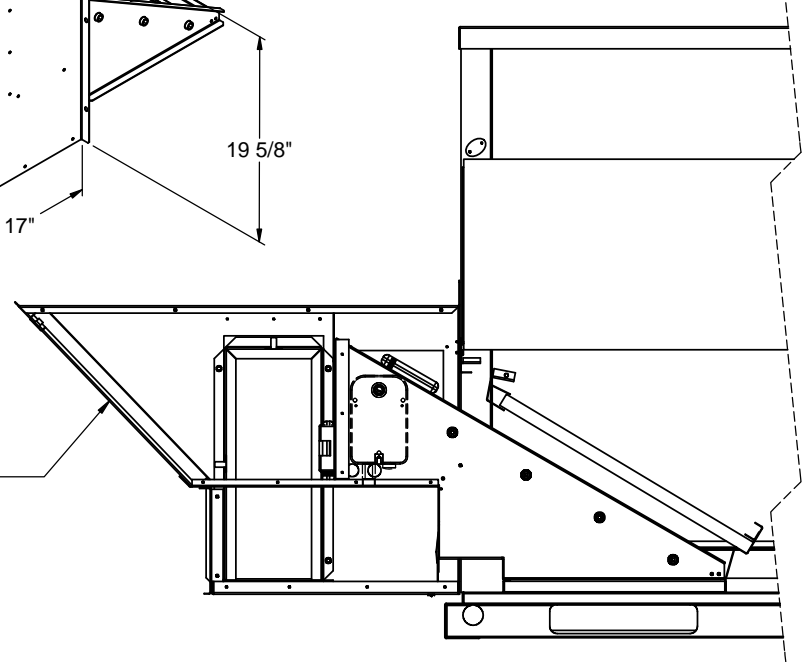

Outside Air Intake



Only Ruskin Company Model CD-60 is AMCA Certified

ProVent P/N

ECODAFF1860AC1
(Actuator Only, 2-10 VDC)

ECODAFF1860DB1
(Fully Modulating Dry Bulb)

ECODAFF1860EN1
(Fully Modulating Enthalpy)

Wt.

50 Lb.

*** IMPORTANT NOTE ***
Heat Pump units require an additional DPDT relay and single phase units require 75VA transformer field provided.

Note: For factory installed LEED economizer option, part number FLOWECAFF1860 must be added.



3847 WABASH DRIVE
MIRA LOMA, CA 91752

PHONE (951) 685-1101
FAX (619) 872-9799

SUBMITTED TO: _____
COMPANY: _____
JOB NAME: _____
EQUIPMENT: _____
NOTES: _____

FORM NO:

ECO-215

DATE:

2/26/2016

PART NUMBER:

ECODAFF1860 Series

REV:

11

DRAWN BY:

CNG