

GF-2200-A OVERVIEW

GreenTrol model GF-2200-A is a high quality economical programmable dual-probe dual-output airflow/temperature measurement and control solution with options for analog air flow, temperature and corresponding PID output (for control of airflow set point) and alarm features. It is designed for installation in specified critical OEM applications where precise air flow and temperature measurement (down to zero flow), and available PID control of air flow set point are required. The GF-2200-A includes two factory calibrated probes and an advanced programmable microprocessor controlled transmitter. A simple user interface with LCD permit selection of analog output options for airflow and/or temperature measurement, and for corresponding PID control signal outputs to maintain airflow set points. Airflow sensor accuracy is typically 3% of reading from 0 to 2,000 FPM (4% max), and temperature accuracy is $\pm 0.15^\circ\text{F}$ [$\pm 0.08^\circ\text{C}$] from -20 to 160°F [-28.9°C to 71.1°C]. Probes are equipped with high reliability bead-in-glass heated thermistors, factory calibrated to NIST traceable standards over the entire operating range. A Field Calibration Wizard feature permits field adjustment of factory calibration if required. A programmable alarm feature includes options for low/high limit and hysteresis; dead band alarm with upper/lower alarms as a percentage of flow; or as a sensor trouble alarm. The alarm output can be configured as dry relay contacts or as an external LED driver (15mA typical). Analog outputs are field-configurable for 0-10VDC, 0-5VDC or 2-10 VDC (20 mA max.) for communication with virtually all modern controls and building automation systems (BAS).

APPLICATIONS

- Available for custom OEM applications where accurate monitoring and control of low air-flows and temperature is required.
- Maximize system efficiency by accurately measuring and controlling separate flows with a single instrument.
- Key in the acquisition of **LEED®** credits for **Energy and Atmosphere** and **Indoor Environmental Quality** when applied in OA applications.

SYSTEM FEATURES

- Advanced Thermal Dispersion (TD) technology ensures accurate, repeatable airflow measurement from zero flow (still air).
- Proprietary sensor design features high reliability bead-in-glass heated thermistors factory calibrated in wind tunnels to NIST traceable standards for placement in more locations than other sensing technologies.
- Variable airflow signal integration to minimize airflow fluctuations (transient wind gusts) at low air flows.
- Programmable relay or LED alarm feature for low or high limit, and operating deadband.
- Versatile Field Calibration Wizard for simple field adjustment if required.
- Simple push-button user interface for simple field configuration.
- Innovative universal brackets and custom factory designed mounting solutions available.

GF-2200-A SPECIFICATIONS

System

Sensor Accuracy*: Airflow: $\pm 3\%$ of reading typical (4% max)
 Temperature: $\pm 0.15^\circ\text{F}$ [$\pm 0.08^\circ\text{C}$]
 Calibrated Range:0 to 2,000 fpm [10.16 m/s]
 Operating Temperature:Sensor: -20 to 160°F [-28.9 to 71.1°C]
 Xmtr: -20 to 120°F [-28.9 to 48.9°C]
 Operating Humidity:0 to 99% non-condensing;
 Transmitter must be protected from exposure to precipitation
 Programmable Modes:Flow/Flow; Flow/Temperature;
 Flow/PID or PID/PID Control;
 Power Requirements:24 VAC (22.8-26.4 VAC) at 8VA max

Transmitter Enclosure

Enclosure Material:Durable housing with cover
 Enclosure Rating:UL94-5VA
 Transmitter Dimensions:3.570 x 6.006 x 1.502 in (HxWxD)
 [90.68 x 152.55 x 38.15 mm], with two integral 0.502 [12.75 mm] mounting flanges.

Sensor Probes

Probe Construction:Type 6063 aluminum

Mounting Brackets:Standard and custom configurations available
 Probe Diameter:0.75 in [19 mm]
 Standard Size:8 inches (203.2 mm)
 Probes / Sensing Nodes:2 probes per transmitter; 1 sensing nodes per probe; 2 nodes total max.
 Probe/Transmitter Cable:Plenum rated cable up to 10 feet [3.05m] with circular DIN plug (Other cable lengths available)

Output Interface

Analog Outputs:Dual non-isolated analog 0-10VDC, 0-5VDC or 2-10 VDC (20 mA max)
 Output Resolution:0.021% of full scale (0-10/2-10VDC) 0.042% of full scale (0-5VDC)
 Output Load:500 ohm minimum (20 mA max)
 Programmable Alarm:Low limit, High limit, dead band alarm (percentage above or below a specified flow) or trouble alarm
 Alarm type:Selectable as LED driver or dry relay contacts, 30VDC/24VAC 3Amps max.
 Field Cal Wizard:Simple field adjustment of factory calibration if required

* Sensor accuracy is the accuracy of the individual sensor. Installed accuracy of the overall airflow station is application-dependent based on application size and resulting sensor density and is typically better than 15% of reading.

TS_GF-2200-A_R1C

GF-2200-A MECHANICAL DETAIL

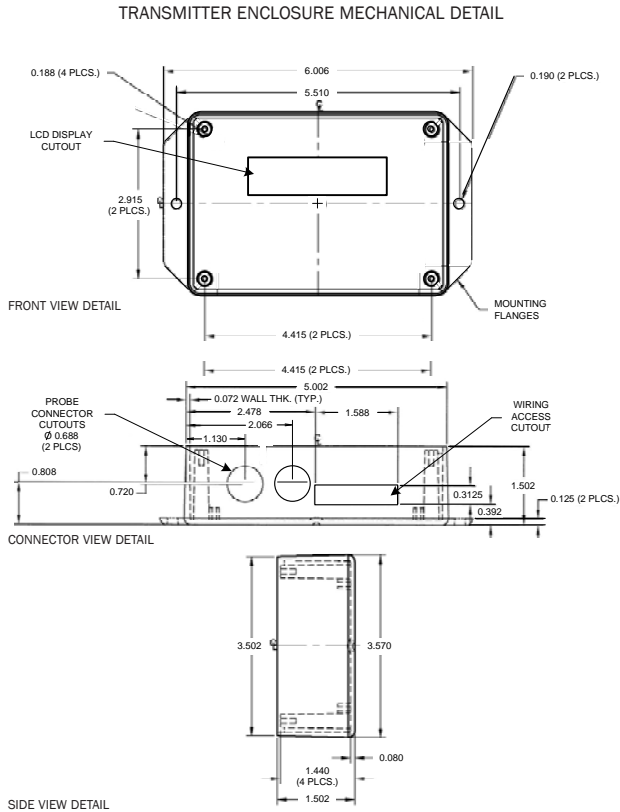

PROBE AND BRACKET MECHANICAL DETAIL

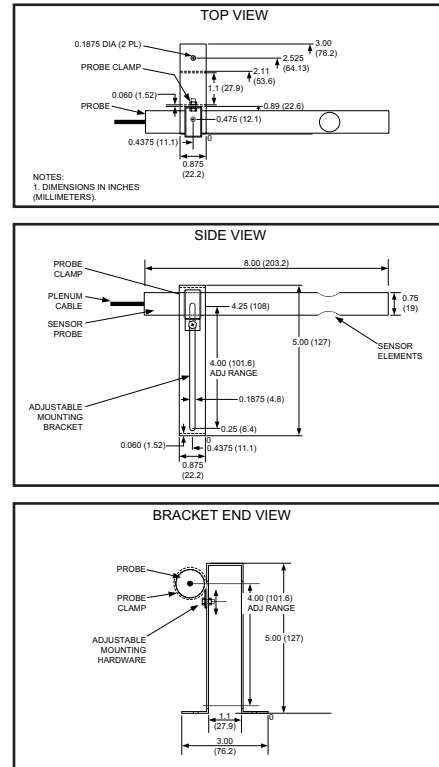

NOTE:
 STANDARD UNIVERSAL BRACKET SHOWN. FACTORY DESIGNED BRACKET SOLUTIONS ARE AVAILABLE FOR ANY MOUNTING APPLICATION.

GF-2200-A TYPICAL WIRING DIAGRAM

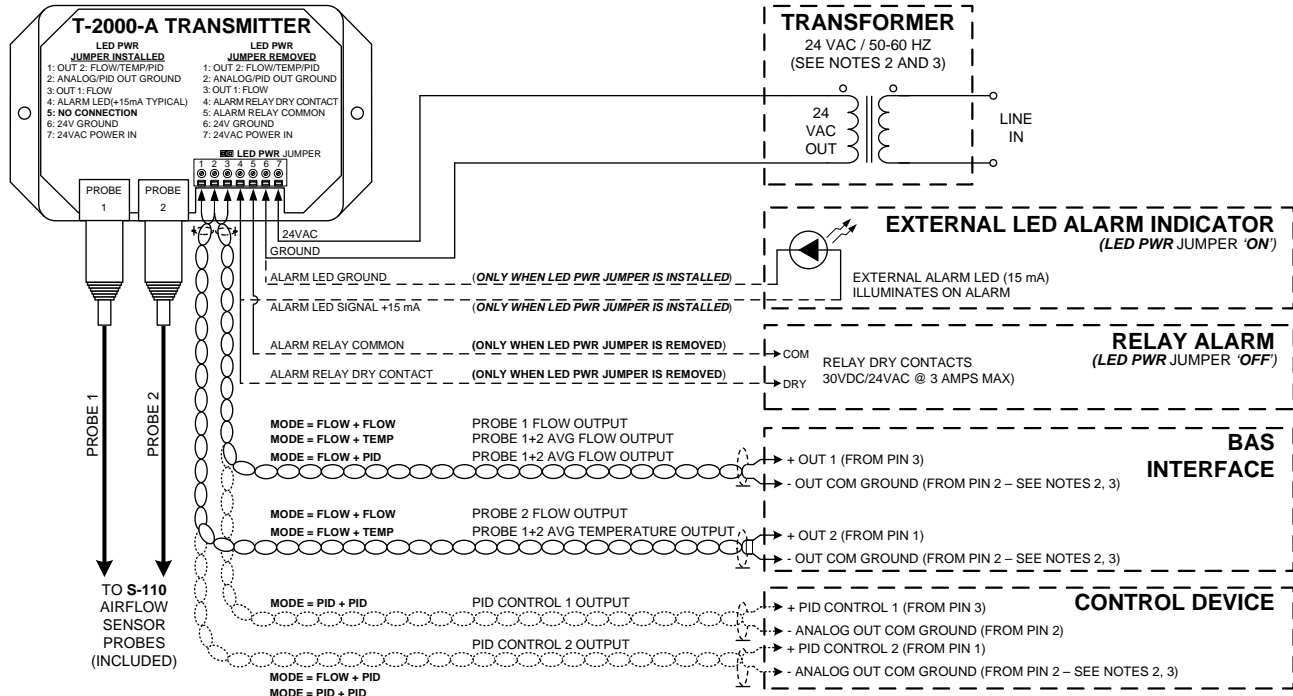

NOTES:

- CONNECT OUTPUT SIGNAL CABLE DRAINS TO EARTH GROUND AT ONE END OF CABLE ONLY.
- THE GF-2200-A IS A NON-ISOLATED DEVICE USING A HALF-WAVE RECTIFIER ON THE 24VAC POWER INPUT. IF MULTIPLE DEVICES ARE POWERED BY THE SAME TRANSFORMER OUTPUT, ALL GND CONNECTIONS MUST BE COMMON, OR AN ISOLATION TRANSFORMER MAY BE USED TO PREVENT EQUIPMENT DAMAGE.
- ALL DEVICES ON MULTIPLE GF-2200-A TRANSMITTER INSTALLATIONS WITH A COMMON 24VAC SOURCE MUST BE WIRED IN-PHASE TO THE SAME TERMINALS (e.g.: PIN 6 TO PIN 6, PIN 7 TO PIN 7).
- SHIELDED TWISTED PAIR (STP) WIRING (SUPPLIED BY OTHERS) IS RECOMMENDED.

TS_GF-2200-A_PL1C