

FEATURES

- Modulating option includes fully programmable (factory set) variable frequency drive controlled by a differential pressure transducer designed to continuously monitor space pressure.
- CO2 controller standard on economizer. Space or duct mounted CO2 sensor provided as option:
 - CO2WM - Wall Mount With LED
 - CO2DM - Duct Mount
- Access door for motor, blower, and blower drives.
- Adjustable motor sheave.
- Motor with automatic internal thermal protection.

DOWN OR HORIZONTAL DISCHARGE CENTRIFUGAL POWER EXHAUST ECONOMIZER FOR ALLIED UNITS

LGH/LCH 092-120H 150S

VOLTAGE	External Static (in. W.G)				FLA	MCA	MOP	Hp	Wt
	0.1	0.2	0.3	0.4					
230V/3Ph	4,200 cfm	4,000 cfm	3,900 cfm	3,800 cfm	5.6	7	10	2	220 Lbs. (Includes Economizer)
460V/3Ph					2.8	3.5	6		

ProVent P/N

CONSTANT VOLUME	MODULATING
PECCBBXDB25C 208/230V 3Ph Selectable Dry Bulb	PECCBBXDB25M 208/230V 3Ph Selectable Dry Bulb
PECCBBXEN25C 208/230V 3Ph Enthalpy	PECCBBXEN25M 208/230V 3Ph Enthalpy
PECCBBXDB46C 460V 3Ph Selectable Dry Bulb	PECCBBXDB46M 460V 3Ph Selectable Dry Bulb
PECCBBXEN46C 460V 3Ph Enthalpy	PECCBBXEN46M 460V 3Ph Enthalpy

PLEASE NOTE:

1. Return air duct, dampers, return air grills are specific for each unit.
2. For proper electrical wire sizing, Provent power exhaust full load amps need to be added to equation.

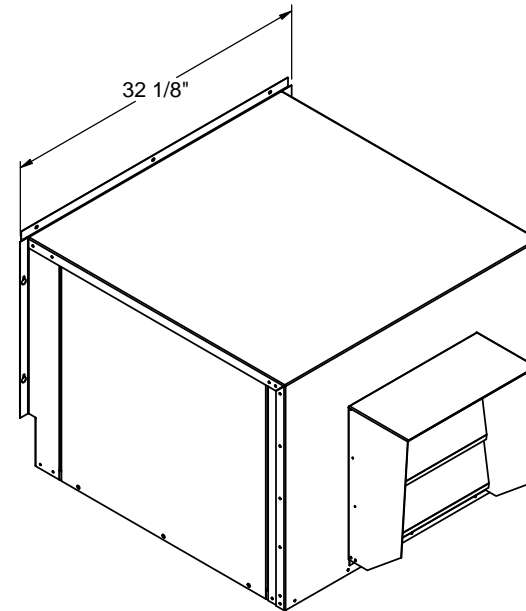
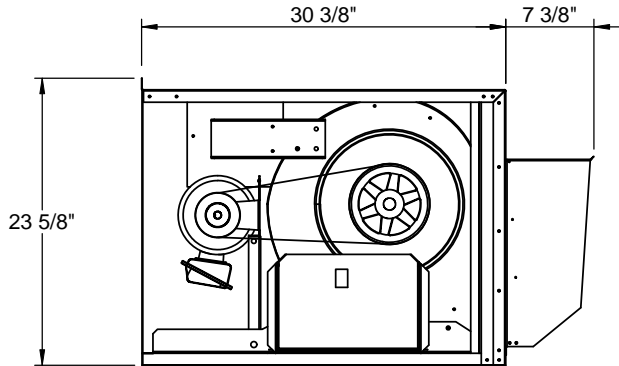

3847 WABASH DR.
MIRA LOMA, CA 91725

PHONE (951) 685-1101
FAX (619) 872-9799

SUBMITTED TO: _____
 COMPANY: _____
 JOB NAME: _____
 EQUIPMENT: _____
 NOTES: _____

FORM NO:
PE-301

DATE:
10/15/2014

PART NUMBER:
PECCBBX SERIES

REV:
2

DRAWN BY:
FMM